

simatic

FM-Stepdrive/SIMOSTEP

Power Controller and 3-Phase Stepping Motors

**SIEMENS**



# SIEMENS

## SIMATIC

### FM-STEPDRIVE/SIMOSTEP Power Controller and 3-Phase Stepping Motors

Functional description

FM-STEPDRIVE/SIMOSTEP

<b>Overview</b>	<b>1</b>
<b>Functional description</b>	<b>2</b>
<b>FM-STEPDRIVE specifications</b>	<b>3</b>
<b>Signal description</b>	<b>4</b>
<b>Mounting</b>	<b>5</b>
<b>Wiring</b>	<b>6</b>
<b>Setup</b>	<b>7</b>
<b>Status indicators and troubleshooting</b>	<b>8</b>
<b>SIMOSTEP specifications</b>	<b>9</b>
<b>Stepping motor parameters and characteristics</b>	<b>10</b>

# SINUMERIK® Documentation

## Printing history

Brief details of this editor and previous editions are listed below.

The status of each edition is shown by the code in the "Remarks" column.

*Status code in "Remarks" column:*

- A ....** New documentation
- B ....** Unrevised reprint with new order No.
- C ....** Revised edition with new status

If factual changes have been made on the page since the last edition, this is indicated by a new edition coding in the header on that page.

<b>Edition</b>	<b>Order No.</b>	<b>Remarks</b>
01.96	6SN1197-0AA70-0YP0	<b>A</b>
01.97	6SN1197-0AA70-0YP1	<b>C</b>
01.97	6SN1197-0AA70-0YP2	<b>C</b>
11.98	6SN1197-0AA70-0YP3	<b>C</b>
01.01	6SN1197-0AA70-0YP4	<b>C</b>
02.05	6SN1197-0AA70-0YP5	<b>C</b>

This documentation was created using WinWord V 7.0, Designer V 7 and Doc-To-Help V 1.6. The reproduction, transmission or use of this document or its contents is not permitted without express written authority. Offenders will be liable for damages. All rights, including rights created by patent grant or registration of a utility model or design, are reserved.

© Siemens AG 1998. All Rights Reserved.

Other functions not described in this documentation might be executable in the control. This does not, however, represent an obligation to supply such functions with a new control or when servicing.

The contents of this publication has been verified for correspondence with the hardware and software described. Nevertheless there may still be some deviations. The information contained herein is verified on a regular basis, and any corrections will be included in the subsequent editions. We should appreciate any suggestions for improvement.

Subject to technical modifications.

## Safety information

This manual contains safety texts which you should always observe for your personal safety and to avoid damage. These texts are identified and emphasized by a symbol and a heading which varies according to the degree of danger:



---

### Danger

means that death, serious injury or severe damage **will** result if proper precautions are not taken.

---



---

### Warning

means that death, serious injury or severe damage **may** result if proper precautions are not taken.

---



---

### Caution

means that minor injury or damage may result if proper precautions are not taken.

---

---

### Note

is used to give special emphasis to important information on the product, handling the product or the relevant part of the documentation.

---

## Qualified personnel

Start-up and operation of the unit shall only be carried out by qualified personnel. Qualified personnel in the sense of the safety information in this manual are those persons who are authorized for setting up, earthing and tagging equipment, systems and circuits according to established safety practices.

## Intended use

The following should be noted:



---

### Warning

This equipment may only be used for the individual applications specified in the catalog and in this documentation and only in conjunction with Siemens approved or recommended third-party equipment and components.

Adequate transport, storage, installation and mounting as well as careful use and thorough maintenance are prerequisites for safe and reliable operation of the product.

---

## Trademarks

SIMATIC® and SINEC® are registered trademarks of the SIEMENS AG.



# Contents

	Page
<b>Overview</b> .....	<b>1-1</b>
<b>Functional description</b> .....	<b>2-1</b>
<b>FM-STEPDRIVE specifications</b> .....	<b>3-1</b>
3.1    Electrical data .....	3-2
3.2    Mechanical data.....	3-5
3.3    Ambient conditions .....	3-5
3.4    Applicable standards, regulations, laws .....	3-6
<b>Signal description</b> .....	<b>4-1</b>
4.1    Pulse interface .....	4-2
4.2    Signal interface .....	4-3
4.3    Signal timing diagrams .....	4-4
<b>Mounting</b> .....	<b>5-1</b>
<b>Wiring</b> .....	<b>6-1</b>
6.1    FM-STEPDRIVE and SIMOSTEP wiring.....	6-2
6.2    Wiring example for FM-353 and FM-NC/FM357 .....	6-4
6.3    Wiring layout for control cabinet .....	6-6
6.4    Network wiring for several axes.....	6-7
6.5    Operating an axis in a safe working area .....	6-10
6.6    Accessories .....	6-12
<b>Setup</b> .....	<b>7-1</b>
<b>Status indicators and troubleshooting</b> .....	<b>8-1</b>
<b>SIMOSTEP specifications</b> .....	<b>9-1</b>
<b>Stepping motor parameters and characteristics</b> .....	<b>10-1</b>
10.1    Basic concepts.....	10-2
10.2    Torque characteristics .....	10-3





# Overview

# 1

The FM-STEPDRIVE is a power controller for controlling a Siemens SIMOSTEP 3-phase stepping motor . The FM-STEPDRIVE has been designed as a module for the SIMATIC S7-300 automation system.

The SIMOSTEP motor series includes the following 3-phase stepping motors:

Table 1-1 SIMOSTEP series stepping motors

Motor type without brake	Nominal torque	Nominal current	Order number
SIMOSTEP 1FL3041	2 Nm	1.8 A	1FL3041-0AC31-0BK0
SIMOSTEP 1FL3042	4 Nm	2.0 A	1FL3042-0AC31-0BK0
SIMOSTEP 1FL3043	6 Nm	2.3 A	1FL3043-0AC31-0BG0
SIMOSTEP 1FL3061	10 Nm	4.1 A	1FL3061-0AC31-0BG0
SIMOSTEP 1FL3062	15 Nm	4.8 A	1FL3062-0AC31-0BG0

Motor type with brake	Nominal torque	Nominal current	Order number
SIMOSTEP 1FL3041	2 Nm	1.8 A	1FL3041-0AC31-0BJ0
SIMOSTEP 1FL3042	4 Nm	2.0 A	1FL3042-0AC31-0BJ0
SIMOSTEP 1FL3043	6 Nm	2.3 A	1FL3043-0AC31-0BH0
SIMOSTEP 1FL3061	10 Nm	4.1 A	1FL3061-0AC31-0BH0
SIMOSTEP 1FL3062	15 Nm	4.8 A	1FL3062-0AC31-0BH0

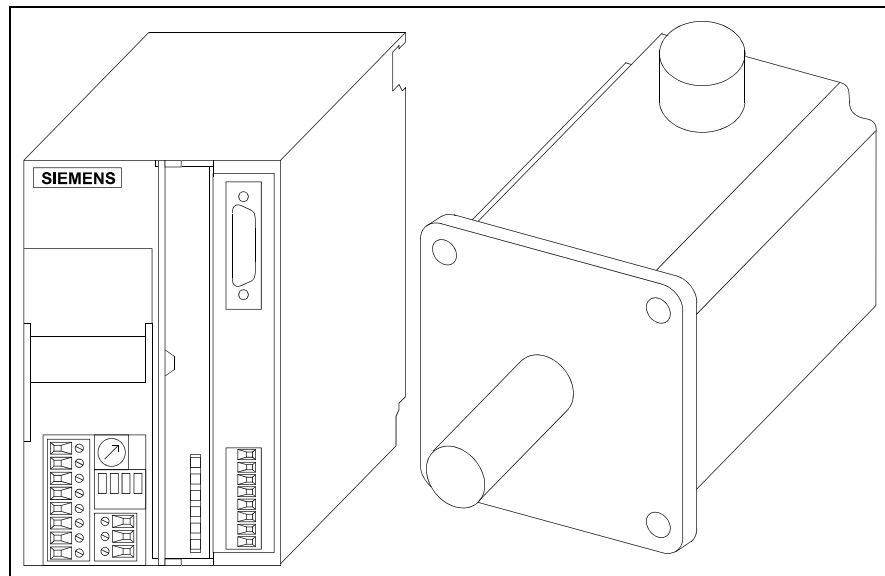

Figure 1-1 FM-STEPDRIVE power controller and SIMOSTEP motor

#### Reference literature

*Elektrische Schrittmotoren und -Antriebe*

Prof. Dr. Erich Rummich, TH Wien

Dr.-Ing. Ralf Gförer, SIG Positec BERGERLAHR GmbH&Co.KG  
and two co-authors.

Expert-Verlag: ISBN 3-8169-0678-8

# Functional description

# 2

The FM-STEPDRIVE power controller has interfaces, switches and indicating elements arranged on the front panel as shown in figure 2-1. The interfaces and parameter switches are visible when the front doors are opened.

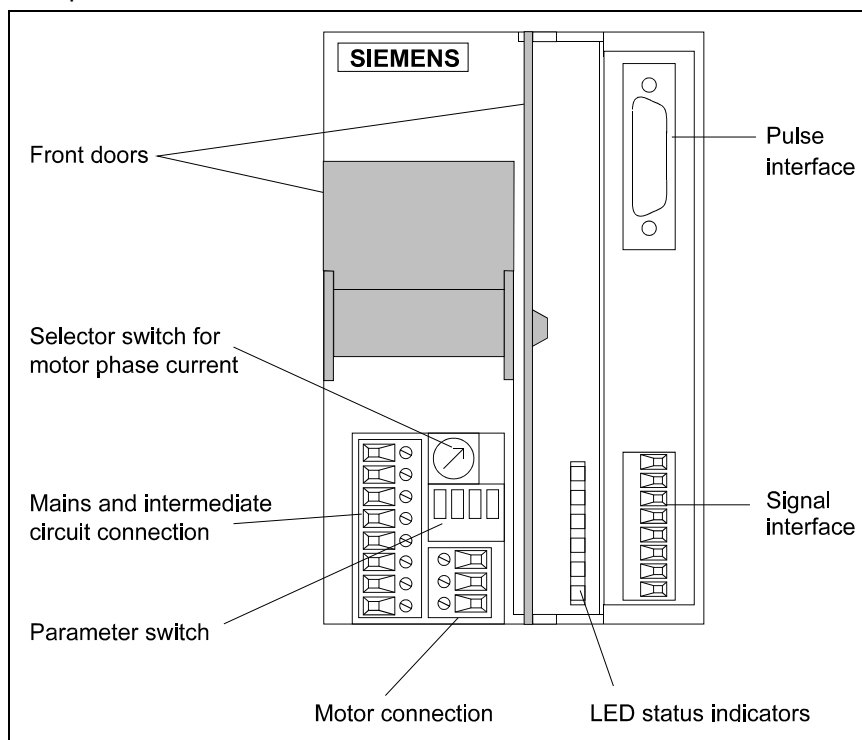

Figure 2-1 FM-STEPDRIVE power controller

### Pulse interface

The pulse interface can be used for controlling the power controller from the master positioning unit using clock signals. With each clock pulse, the motor moves one step. In addition, a PWM signal can be used for adjusting the phase current of the stepping motor between 0 and 100 %.

*Input signals:* PULSE (clock), DIR (sense of rotation), ENABLE (enables the amplifier), PWM (current control).

*Output signal:* READY1\_N (readiness).

### Signal interface

The GATE\_N input of the signal interface can be used for enabling or disabling the clock signals for motor control fed to the PULSE input. The ENABLE\_N input has the same function as the ENABLE input for the pulse interface although it is activated via 24 V. In addition, the ZERO output can be used for evaluating the zero signal of the internal ring counter.

*Input signals:* GATE\_N (enabling/disabling the clock signal)  
ENABLE\_N (enables the amplifier)

*Output signals:* ZERO (ring counter zero signal), READY2 (readiness),  
MSTILL (Motor standstill)

### Mains and intermediate circuit connection

The mains connection supplies the power controller with 115 V or 230 V AC. The intermediate circuit connection may be used for dissipating surplus recovery energy of the motor.

- Motor connection** A 3-phase stepping motor of the SIMOSTEP series can be connected to the motor connection.
- Current and parameter switches** These switches are used for setting the motor phase current, the number of steps (500, 1000, 5000, 10 000 steps/revolution) and the current reduction (to 60 % at motor standstill).
- LED status indicators** To indicate readiness and any malfunctions (short-circuit between motor phases, supply overvoltage/undervoltage, power controller overtemperature, no GATE\_N signal).
- Fan** A fan is installed in the FM-STEPDRIVE power controller.

The block diagram shown in figure 2-2 illustrates the most important functional groups of the FM-STEPDRIVE power controller.

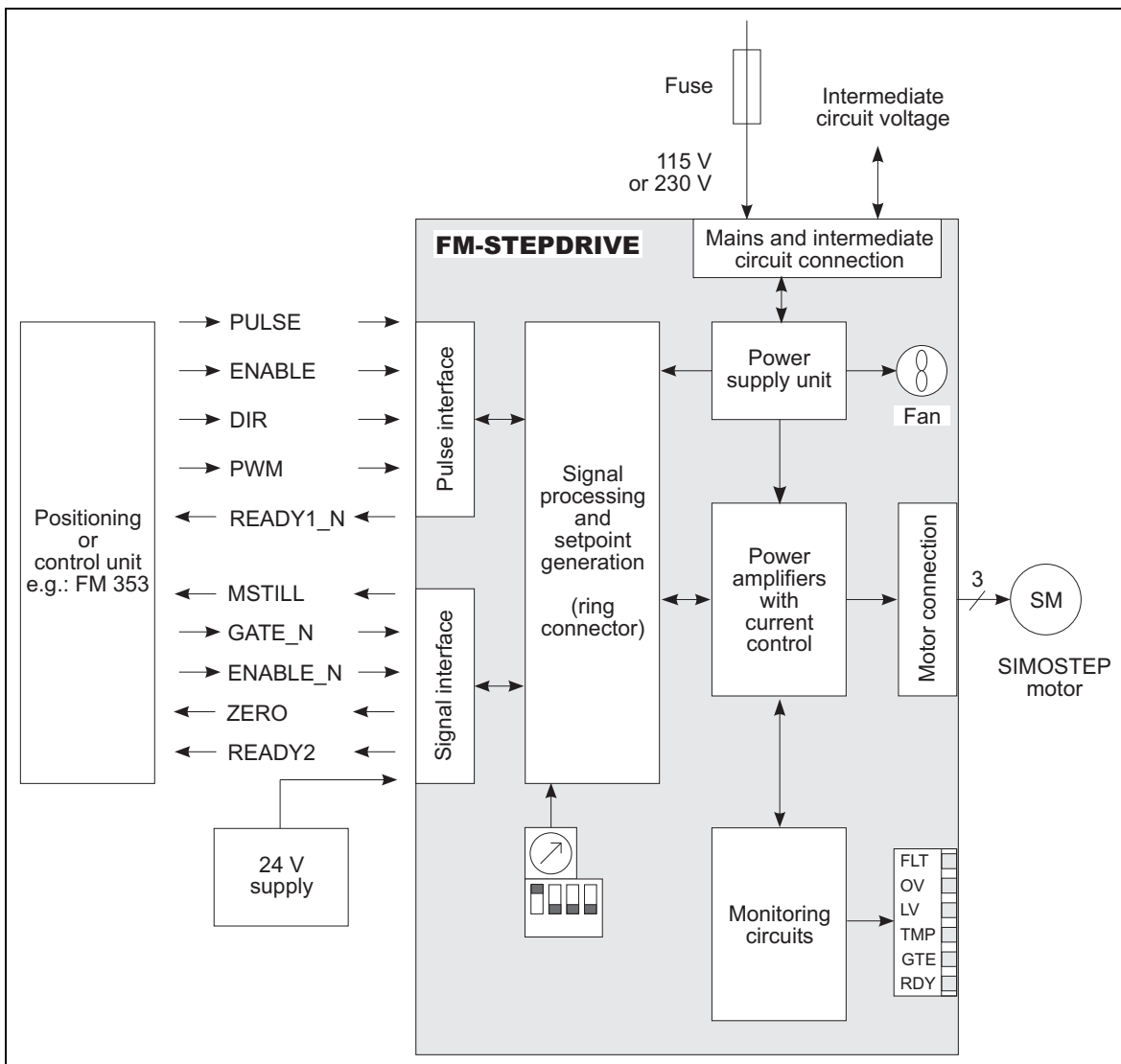

Figure 2-2 FM-STEPDRIVE block diagram



# FM-STEPDRIVE specifications

# 3

3.1	Electrical data .....	3-2
3.2	Mechanical data.....	3-5
3.3	Ambient conditions .....	3-5
3.4	Applicable standards, regulations, laws .....	3-6

### 3.1 Electrical data

<b>Mains connection</b>	Mains voltage	115 V or 230 V AC Tolerance: -20% / +15% Frequency range: 47 Hz to 63 Hz
	External back-up fuse	16 A max. ("K" or "C" characteristic)
	Input current	8 A max. at 115 V/4.5 A at 230 V
	Starting current	75 A max.
	Mains buffering time	> 10 ms at motor standstill
	Maximum power loss	80 W
	<b>Intermediate circuit connection</b>	Intermediate circuit voltage
Open-close cycle (during operation and after fault rectification)		> 5 s
<b>Motor connection</b>	Phase current	1.7 A to 6.8 A 6.8 A max. at an ambient temperature of 50°C and vertical mounting position
		4.8 A max. at an ambient temperature of 60°C and vertical mounting position
		4.8 A max. at an ambient temperature of 40°C and horizontal mounting position
	Motor voltage	3 x 325 V (connected to mains)
Motor cable	Trailing cable with double shield 3 x 1.5 CC	
	Length	50 m max.
	Wire cross-section	3 x 1.5 mm <sup>2</sup>



## Pulse interface

### Note

All signals are PELV (protected extra low voltage) signals as defined by VDE 0160.

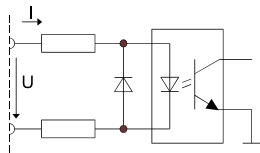

### Pulse interface inputs

PULSE (clock), DIR (sense of rotation), ENABLE (power controller enable), PWM (current control). For a signal description, see chapter 4.

5 V optocoupler inputs:

Voltage control:

$U_{\text{high, min}}$	=	2.5 V	
$U_{\text{high, max}}$	=	5.25 V	
$U_{\text{low, max}}$	=	0.4 V	
$U_{\text{low, min}}$	=	-5.25 V	$I_{\text{max}} = 30 \text{ mA}$

Current control:

$I_{\text{high, min}}$	=	7 mA	
$I_{\text{high, max}}$	=	25 mA	
$I_{\text{low, max}}$	=	0.2 mA	
$I_{\text{low, min}}$	=	-25 mA	$U_{\text{max}} = 5.25 \text{ V}$

### Note

It is recommended to use push-pull control for reasons of noise suppression.

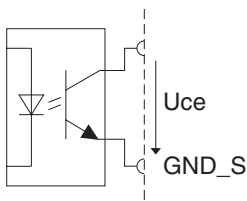

### Pulse interface output

READY1\_N (readiness). For a signal description, see chapter 4. Optocoupler output (no reverse-polarity protection, not short-circuit protected):

$U_{\text{ce}}$ :	30 V max.
$U_{\text{ce,sat}}$ :	< 1.0 V at 10 mA



### Warning

This output is not short-circuit protected and does not feature reverse-polarity protection.

GND\_S: System ground, internally connected

## Signal interface

### Note

Alls signals are PELV (**protected extra low voltage**) signals as defined in VDE 0160.

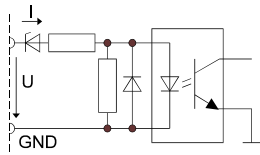

### Signal interface input

GATE\_N (enable/disable the clock signal). ENABLE\_N (enables the amplifier). For a signal description, see chapter 4.

24 V standard PLC optocoupler input:

$U_{\text{high, min}}$	= 15 V	$I_{\text{high, min}}$	= 2 mA	Input open corresponds to low signal.
$U_{\text{high, max}}$	= 30 V	$I_{\text{high, max}}$	= 15 mA	
$U_{\text{low, max}}$	= 5 V	$I_{\text{low, max}}$	= 0.2 mA	
$U_{\text{low, min}}$	= -3 V	$I_{\text{low, min}}$	= -15 mA	

Max. transient overvoltage

35 V/500 ms

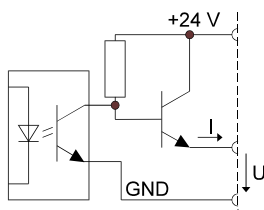

### Signal interface outputs

READY2 (readiness), ZERO (ring counter zero signal), MSTILL (Motor standstill). For a signal description, see chapter 4.

24 V standard PLC output READY2 (overload and short-circuit protected):

$U_{\text{high}}$	24 V supply voltage
Voltage drop	3 V max. at 70 mA
Output current	70 mA
Sustained short-circuit current	0.6 A max.
Peak current	5 A max. for 50 ms
$U_{\text{low}}$	Output open
Leakage current	150 $\mu$ A max.

24 V standard PLC output ZERO (overload and short-circuit protected):

Voltage drop	3 V max. at 30 mA
Output current	30 mA max.
other data as for output READY2	

### External 24 V supply for signal interface

#### Note

The 24 V voltage supply must meet the specifications of DIN 19240.

Voltage range	18.5 V to 30.2 V DC
Ripple	3.6 Vpp
Input current	1.5 A max.
Transient overvoltage	35 V / 500 ms max.

### 3.2 Mechanical data

Dimensions (H x W x D)	125 x 80 x 117 mm
Weight	890 g

### 3.3 Ambient conditions

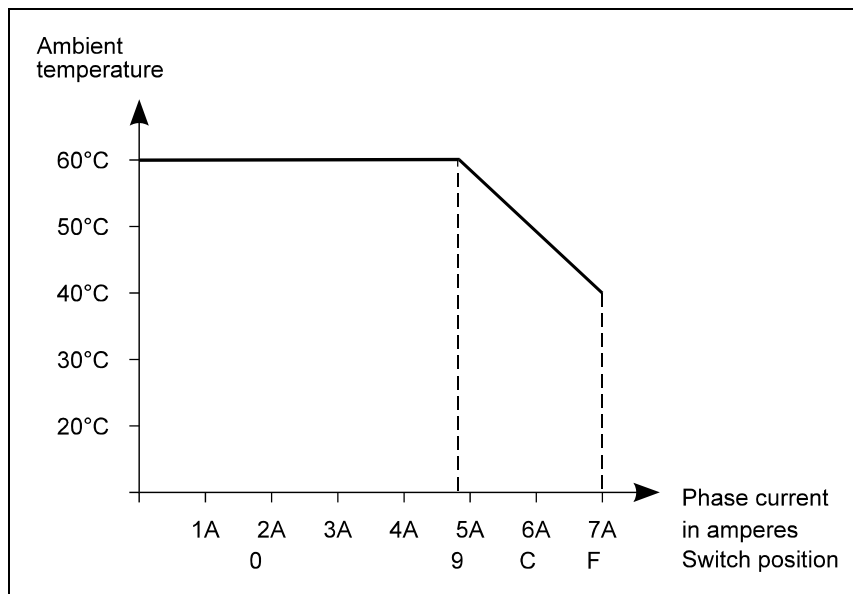

Figure 3-1 Interrelation between phase current and ambient temperature

Non-condensing

Transport and storage temperature -40°C to +70 °C

Vibration strain during operation

10 Hz to 58 Hz	0.075 mm deflection
over 58 Hz to 500 Hz	8.9 m/s <sup>2</sup>

Vibration strain during transport (packaged)

5 Hz to 9 Hz	3.5 mm deflection
over 9 Hz to 500 Hz	10 m/ s <sup>2</sup>

Shock 15 g 11 ms

Free fall non-packaged 100 mm  
packaged 500 mm

Drop and topple admissible

Continuous sound pressure level <50 dB(A)

### 3.4 Applicable standards, regulations, laws

**The following standards, regulations and laws must be observed when operating the FM-STEPDRIVE:**

- DIN EN 60204 Part 1 (VDE 0113) Electrical equipment of machines
- DIN VDE 0100                                      Erection of power installations with nominal voltages up to 1000 V
- DIN VDE 0106                                      Protection against electric shock
- DIN VDE 0470 (and: IEC 529)                  IP degrees of protection
- DIN VDE 0875 (EN 55011)                      Radio interference suppression of electrical appliances and systems
- DIN EN 954-1                                      Safety of machines  
Safety-related parts of control systems  
General design guidelines

If you intend to use the FM-STEPDRIVE power drive in a residential area, the limit values of the following standards must also be observed:

- EN 60555    Disturbances in electricity supply networks caused by household appliances and similar equipment
- EN 55022, Class B                                  Limit values and measurement methods for information technology equipment
- DIN EN 61000 Part 3-2                              Electromagnetic compatibility

In case of high interference levels, additional measures must be taken. We recommend to provide for EMC design of cabinets, e.g. 8MC cabinets, (-> catalog NV 21).

**The following standards, regulations and laws have been observed when developing the FM-STEPDRIVE:**

- UL 508    Industrial control equipment
- CSA C22.2 No 142                                      Process control equipment

# 4

## Signal description

4.1	Pulse interface .....	4-2
4.2	Signal interface .....	4-3
4.3	Signal timing diagrams .....	4-4

The signals and timing diagrams for the pulse and signal interfaces are described in the following sections.

### 4.1 Pulse interface

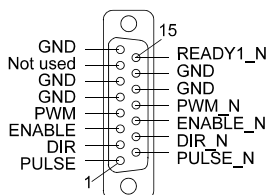

The pulse interface has four 5 V optocoupler inputs and one optocoupler output.

**Note**

The technical data of the pulse interface are described in chapter 3.

The signal timing of the inputs/outputs is described in chapter 4.3.

**Inputs:**

- PULSE (clock)**                      To start motor shaft rotation, rectangular clock pulses must be supplied to the PULSE input. Each positive pulse edge triggers one motor step if the power controller is in ready status and the GATE\_N input is energized (24 V).  
The sense of rotation is preset with the direction input (DIR).
- DIR (sense of rotation)**        When the DIR signal input is deenergized, the motor turns in a clockwise direction (as seen from front towards motor shaft). When this signal input is energized, the motor turns in a counterclockwise direction (as seen from front towards motor shaft). The sense of rotation can also be inverted by interchanging two motor phase leads.
- ENABLE (enable)**                When the ENABLE input is energized, the power controller is enabled. After approx. 500 ms, the power controller reports readiness via the READY1\_N and READY2 outputs and the motor is energized. If 24 V are present at the GATE\_N input of the signal interface, clock pulses can be supplied to the PULSE input.
- PWM (current control)**         The set motor phase current can be modified using a pulse width modulation signal on the PWM input in the range from 0% to 100% (frequency range 10 kHz to 20 kHz). The phase current is determined by the pulse/pause ratio of the PWM signal. If the signal input is deenergized, the set phase current flows. If the signal input is energized, the motor phase current is switched off. When the motor is stopped, it does not have any holding torque.

**Output:**

- READY1\_N (readiness)**        When the ENABLE input is activated, the power controller reports readiness via the READY1\_N output. When the power controller is ready, the READY1\_N output has low resistance. If 24 V are present at the GATE\_N input of the signal interface, clock pulses can be supplied to the PULSE input.  
In case of a power controller fault, or if a power controller enable signal has not been received via the ENABLE input, the READY1\_N output has high resistance.

## 4.2 Signal interface

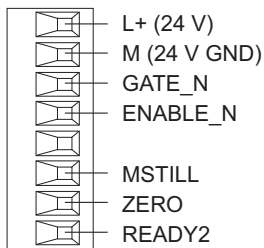

The signal interface has two 24 V optocoupler inputs and two optocoupler outputs.

---

### Note

The technical data of the pulse interface are described in chapter 3.

The signal timing of the inputs/outputs is described in chapter 4.3.

---

### Inputs:

**GATE\_N**  
(enable/disable pulses)

With 24 V at the GATE\_N input, the pulses active on the PULSE input are used for controlling the stepping motor. With 0 V or open input GATE\_N, active pulses are disabled. This function can be used in a multi-axis system for selecting individual axes.

This input is displayed via the GTE LED (see page 8-2).

**ENABLE\_N** (enabling the amplifier)

When the ENABLE\_N input is energized, the power controller is enabled. After approx. 500 ms, the power controller reports readiness via the READY1\_N and READY2 outputs and the motor is energized. If 24 V are present at the GATE\_N input of the signal interface, clock pulses can be supplied to the PULSE input.

### Outputs:

**ZERO** (ring counter zero signal)

When the internal ring counter is zero, 24 V are present on the ZERO output. Reference movements with step accuracy can be performed by evaluating the ZERO signal. At a motor speed of 300 revolutions/minute, the pulse width of the ZERO signal is equivalent to the duration of the PULSE signal period.

At a higher motor speed, the pulse width of the ZERO signal is reduced.

**READY2**  
(readiness)

When the ENABLE input is activated, the power controller reports readiness via the READY2 output. When the power controller is ready, 24 V are present on the READY2 output. If 24 V are present at the GATE\_N input of the signal interface, clock pulses can be supplied to the PULSE input. In case of a power controller fault, or if a power controller enable signal has not been received via the ENABLE input, the READY2 output has high resistance.

**MSTILL**  
(Motor standstill)

With the GATE\_N input, the clock signal at the PULSE input can be disabled so that the motor is brought to a standstill.

The motor standstill enforced by GATE\_N is acknowledged by the MSTILL signal.

At 0 V or if the GATE\_N input is open, 24 V are present at the MSTILL output; the motor shaft cannot move.

Applying 24 V to the GATE\_N input is acknowledged by 0 V on the MSTILL output, and the motor shaft can move again.

### 4.3 Signal timing diagrams

The timing diagrams below illustrate the timing of the input/output signals of the pulse and signal interfaces.

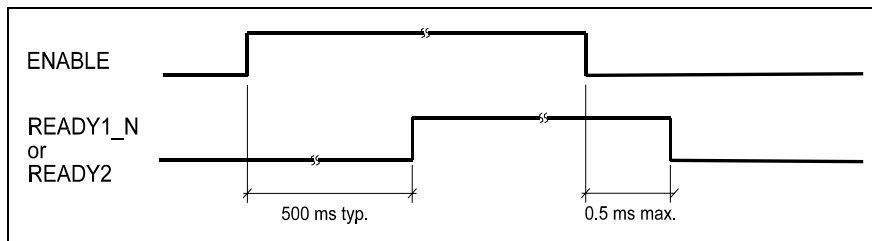

Figure 4-1 ENABLE/READY timing diagram

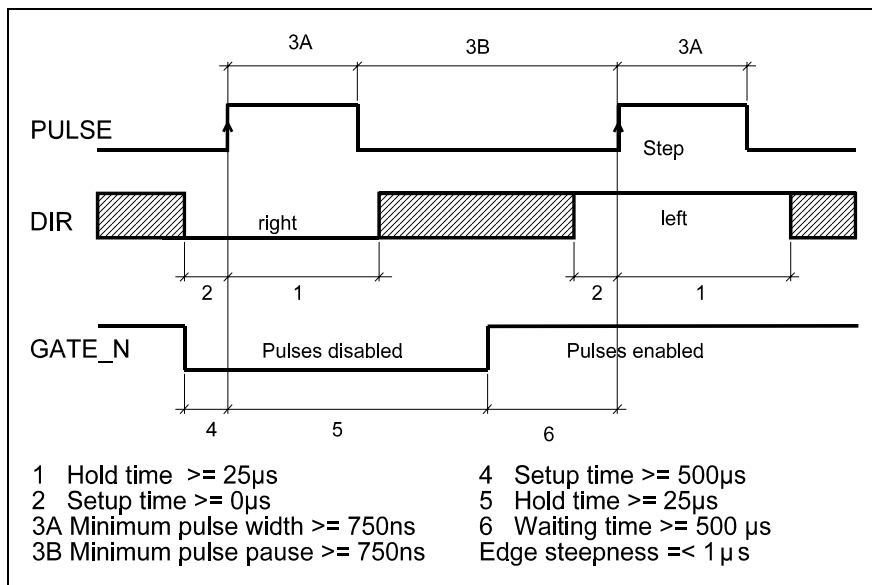

Figure 4-2 PULSE/DIR/GATE\_N timing diagram

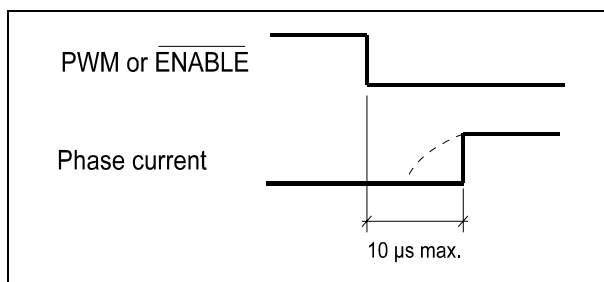

Figure 4-3 PWM or ENABLE and motor phase current timing diagram

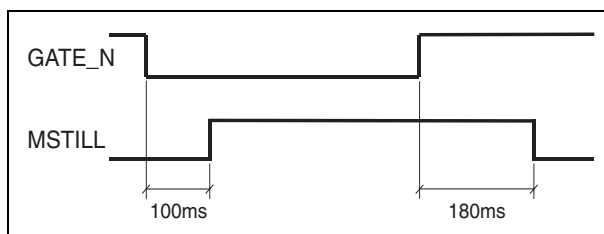

Figure 4-4 GATE\_N/MSTILL timing diagram



# Mounting

# 5

**Danger**

Voltage must be disconnected whenever mounting work is carried out.

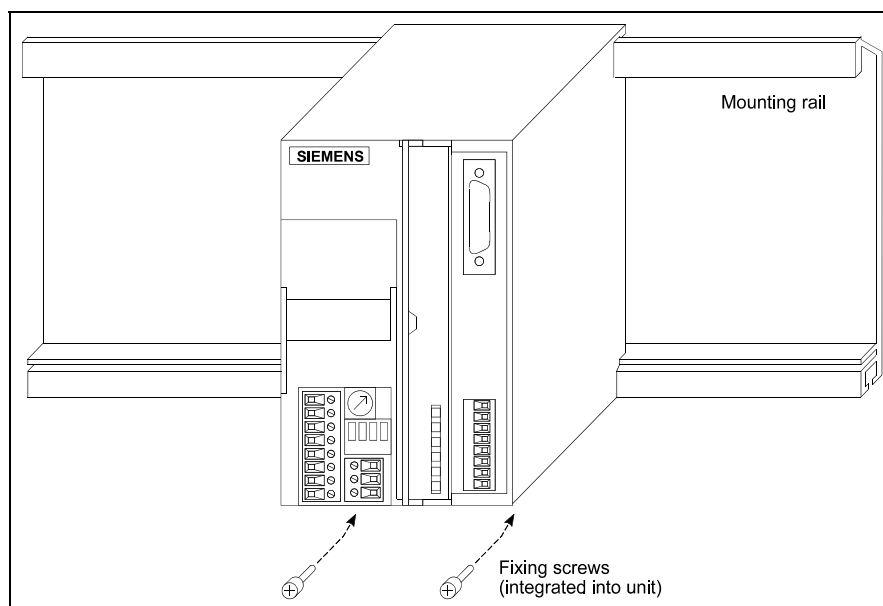

Figure 5-1 Mounting the FM-STEPDRIVE power controller

Mount the FM-STEPDRIVE as follows:

1. Hook the FM-STEPDRIVE to the mounting rail and let it down.
2. Fasten the FM-STEPDRIVE using the two screws at the bottom of the unit.

**Note**

A fan is installed in the power controller. When mounting, leave 5 cm of space for the air flow at the top and bottom of the unit.

Units must not be mounted on top of each other without a partition.

# Wiring

# 6

6.1	FM-STEPDRIVE and SIMOSTEP wiring.....	6-2
6.2	Wiring example for FM-353 and FM-NC/FM357 .....	6-4
6.3	Wiring layout for control cabinet .....	6-6
6.4	Network wiring for several axes.....	6-7
6.5	Operating an axis in a safe working area .....	6-10
6.6	Accessories .....	6-12

## 6.1 FM-STEPDRIVE and SIMOSTEP wiring

Wire the FM-STEPDRIVE power controller and the SIMOSTEP series motor in accordance with figure 6-1.

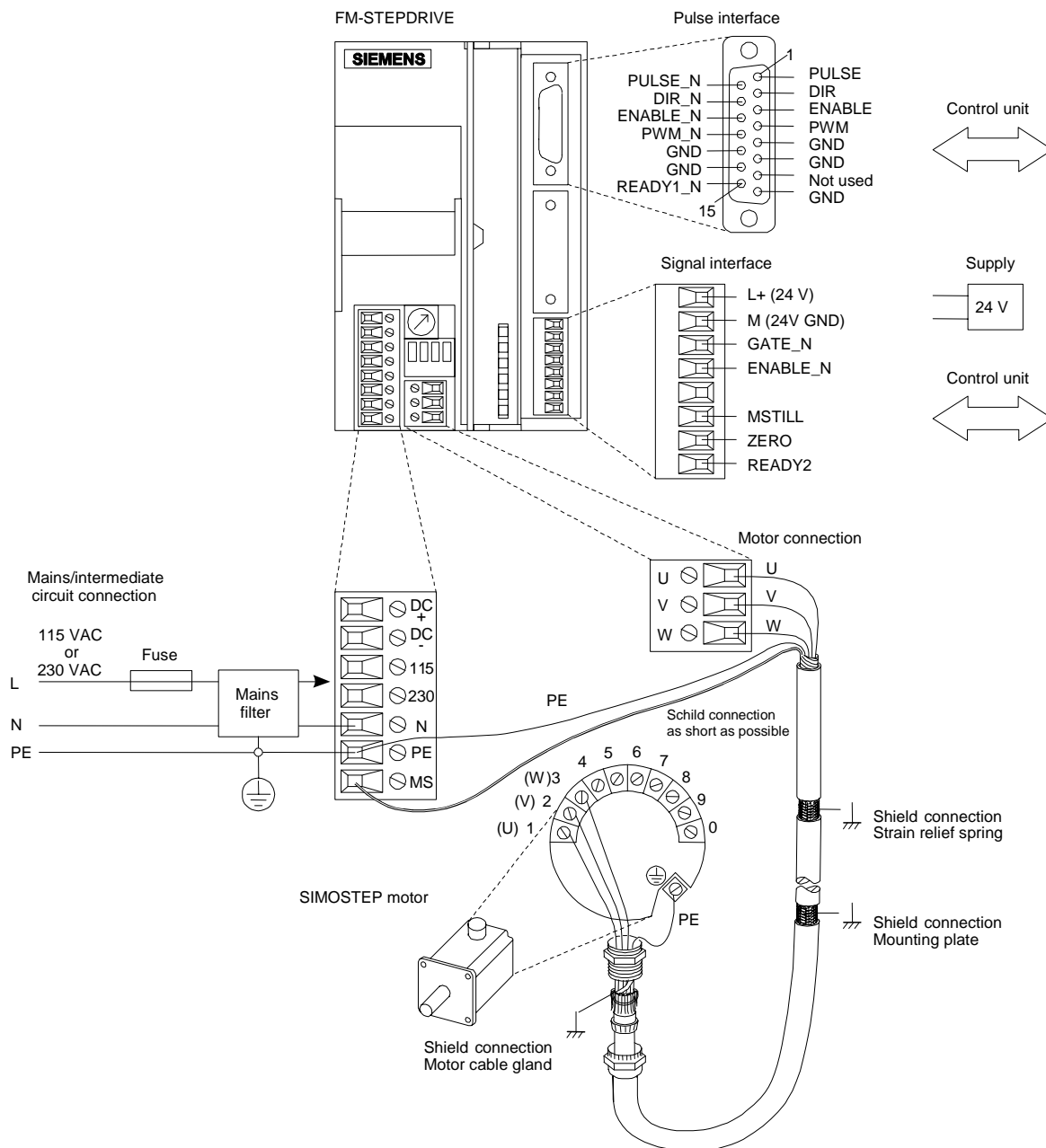

Figure 6-1 FM-STEPDRIVE and SIMOSTEP wiring



### Danger

The supply voltage must be disconnected whenever wiring work is carried out. When the supply voltage is connected, high voltages are present on the mains, intermediate circuit and motor connections. Never touch these connections when the unit is switched on, since this constitutes a danger of death or severe injuries.

**Mains connection**

The unit must be protected by an external 16 a type Kor C standard fuse.

**Danger**

If the neutral conductor is connected, the three-phase power supply requires that the individual phases and neutral be connected/disconnected simultaneously. In order to avoid overvoltage.

In order to fulfil the EMC requirements, a mains filter must be inserted into the mains supply line (see chapter 6.4).

**Intermediate circuit connection**

With multi-axis wiring *and* single-phase mains connection, the intermediate circuit connections DC+ and DC- can be interconnected for energy exchange between the power controllers. This is recommended when considerable masses must be accelerated and decelerated within a short time.

**Motor wiring**

For the cable connection in the motor terminal panel, unscrew the four Phillips screws of the terminal panel.

The PE wire and the shield of the motor cable must be connected on the motor and the device end as shown in figure 6-1.

The protective conductor connection on the motor is usually established via the motor fastening components. If this connection should be insufficient, the protective conductor may be connected to the external terminal of the motor.

A shielded 3-wire standard cable can be used for connecting the motor (see accessory table, chapter 6.6).

The cable shield must be clamped with the motor cable gland on the motor and connected to the strain relief spring on the power controller (remove the sheath at the strain relief element).

Behind the strain relief element, the cable sheath should reach as far as possible to the motor connection on the FM-STEPDRIVE.

At the cable entry into the cabinet, the cable shield must be connected to a grounded shield terminal (remove the sheath at the terminal).

**Pulse interface**

Ready-made cables with sub-D connectors can be used for connecting the pulse interface of the FM-STEPDRIVE power controller to the positioning module FM-353 or the FM-NC/FM357 controller (see accessory table, chapter 6.6).

For a wiring example, see chapter 6.2.

**Signal interface**

The signal interface must be supplied with 24 V DC from an external power supply unit.

The 24 V supply must meet the requirements of the DIN VDE 19240 standard. For a wiring example, see chapter 6.2.

## 6.2 Wiring example for FM-353 and FM-NC/FM357

### Wiring with FM-353 positioning module

The following figure illustrates the wiring layout for connecting the pulse interface to the FM-353 positioning module:

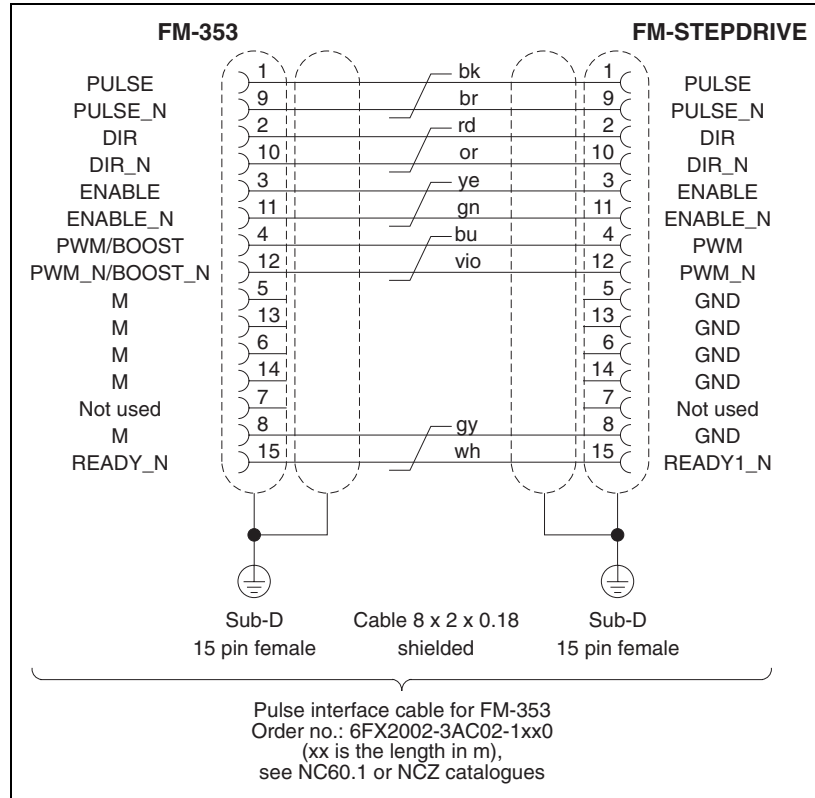

Figure 6-2 Connecting the FM-STEPDRIVE power controller to FM-353

The FM-353 positioning module can evaluate the READY2 or ZERO output signals (refer to manual on SIMATIC S7 positioning module FM 353, order no. 6ES7 353-1AH00-7AG0). Depending on the operating mode used on the FM-353, the RM-P input of the 20-pin front panel connector of the FM-353 must be wired to the ZERO output or to the READY2 output of the signal interface on the FM-STEPDRIVE power controller. The following figure illustrates the wiring layout of the signal interface with common voltage supply:

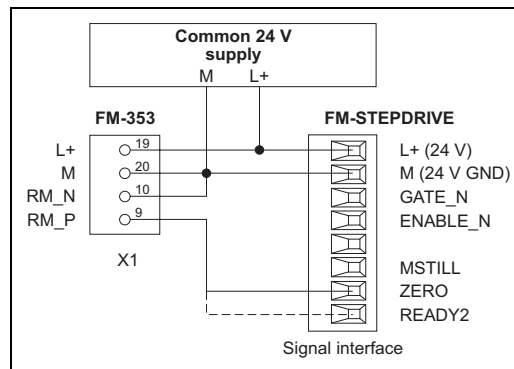

Figure 6-3 Signal interface wiring layout for connection to FM-353

**Multi-axis wiring with FM-NC/FM357 controller**

The following figure illustrates the wiring layout for connecting three FM-STEPDRIVE power controllers and one drive with a ±10V interface to the FM-NC/FM357 controller:

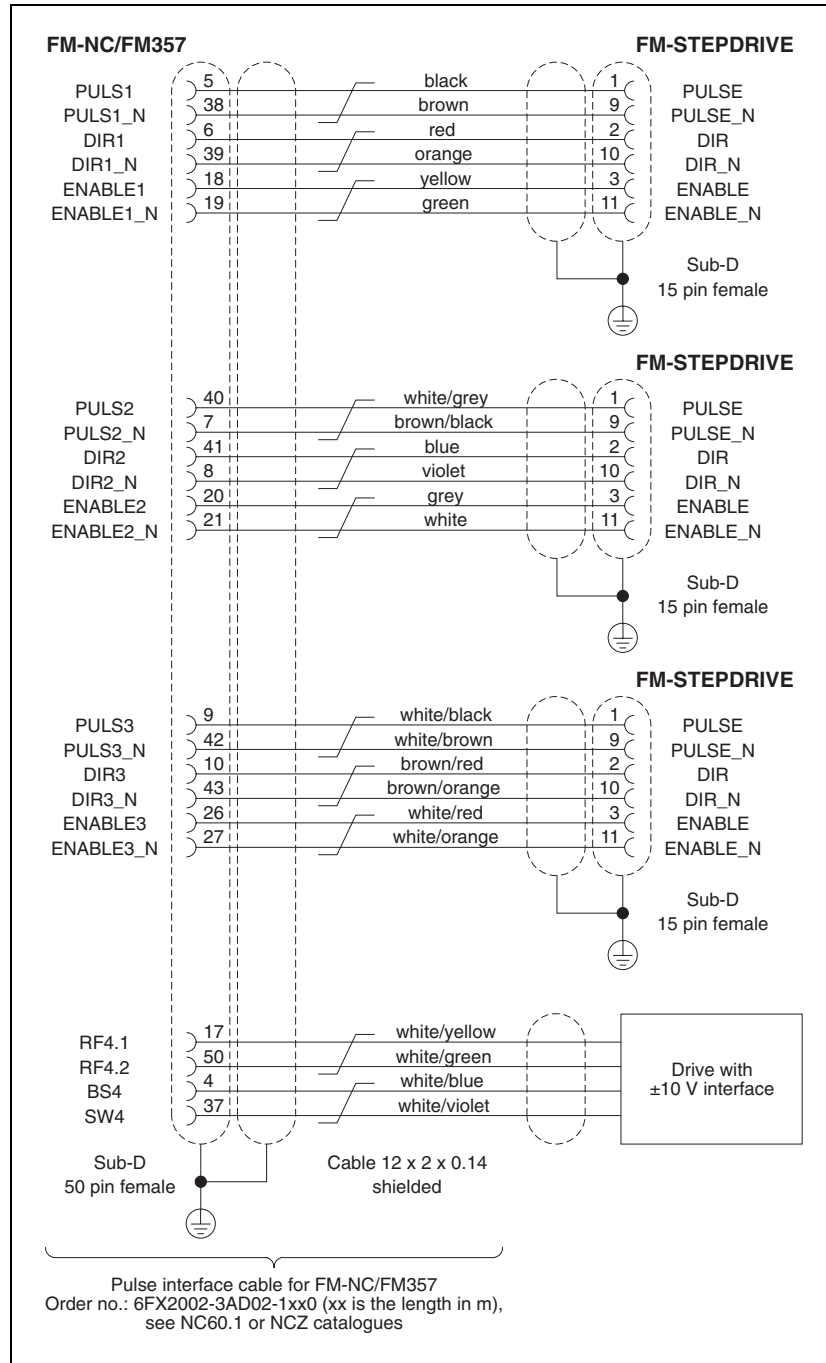

Figure 6-4 Connecting three FM-STEPDRIVEs and one drive with ±10 V interface to the FM-NC/FM357 controller

**Note**

24 V must be applied on the GATE\_N input of the FM-STEPDRIVE signal interface for pulse enabling.

### 6.3 Wiring layout for control cabinet

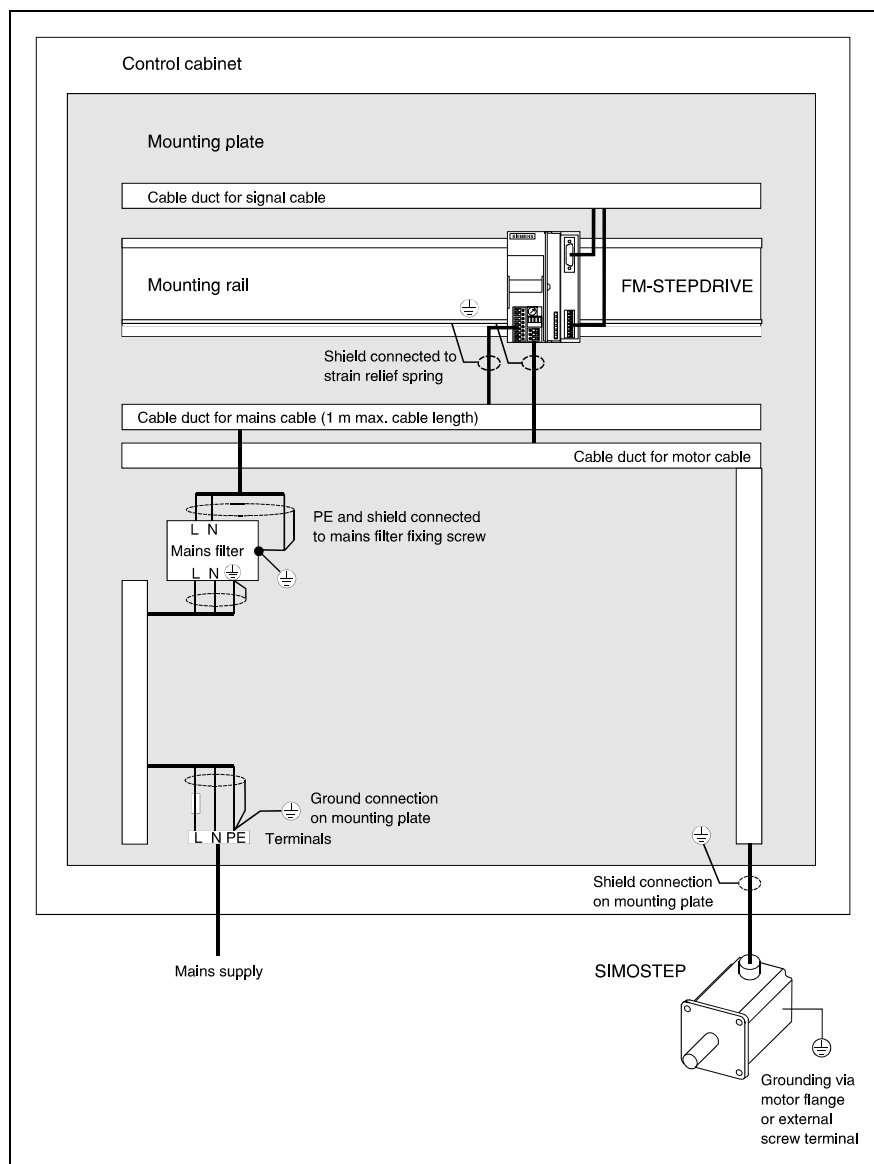

Figure 6-5 Wiring layout for control cabinet

#### Note

For reasons of noise immunity, the mains, motor and signal cables must be run separately and shielded on both ends. The mounting rail and the mains filter must be mounted surface to surface with the mounting plate.

#### Note

For FM-STEPDRIVE and SIMOSTEP wiring, see figure 6-1.



## 6.4 Network wiring for several axes

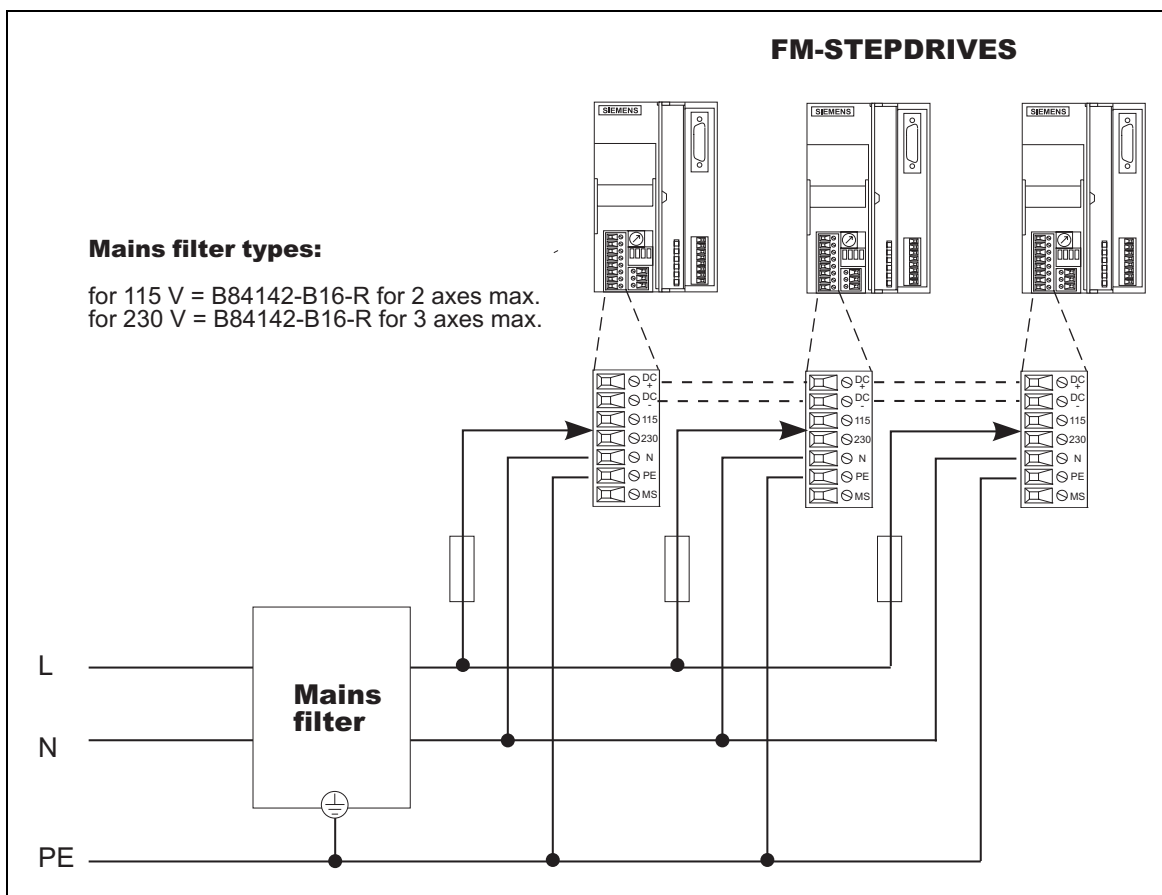

Figure 6-6 Multi-axis wiring with single-phase mains connection

### Note

The intermediate circuit connections (DC+ and DC-) can be interconnected for energy exchange between the power controllers if considerable masses must be accelerated and decelerated within a short time.

### Note

The mains connection cables must be shielded on both ends.

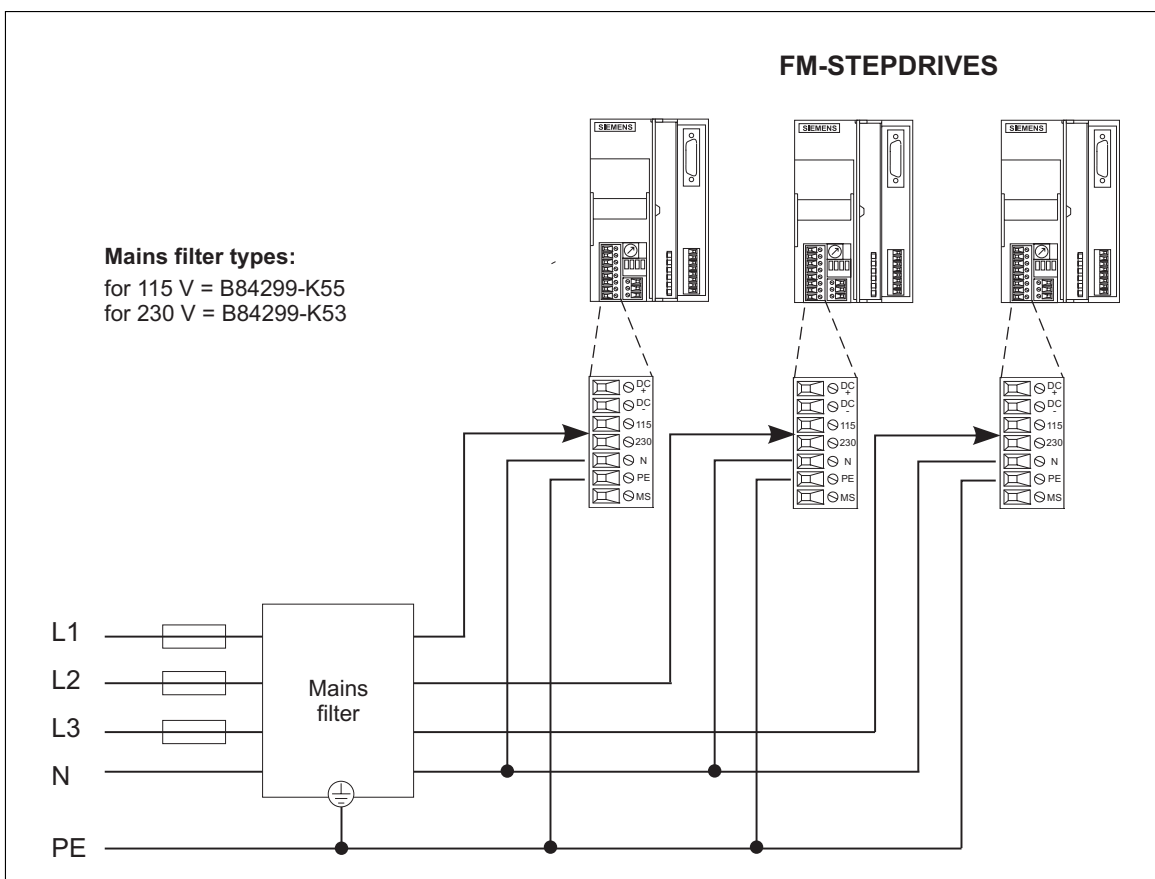

Figure 6-7 Multi-axis wiring with a three-phase mains connection (115 V or 230 V between phase and neutral)

**Note**

The intermediate circuit connections (DC+ and DC-) of the power controllers must not be interconnected!

**Note**

The mains connection cables must be shielded on both ends.



**Danger**

In order to avoid overvoltage, the three-phase power supply requires that the individual phases and neutral be connected / disconnected simultaneously.

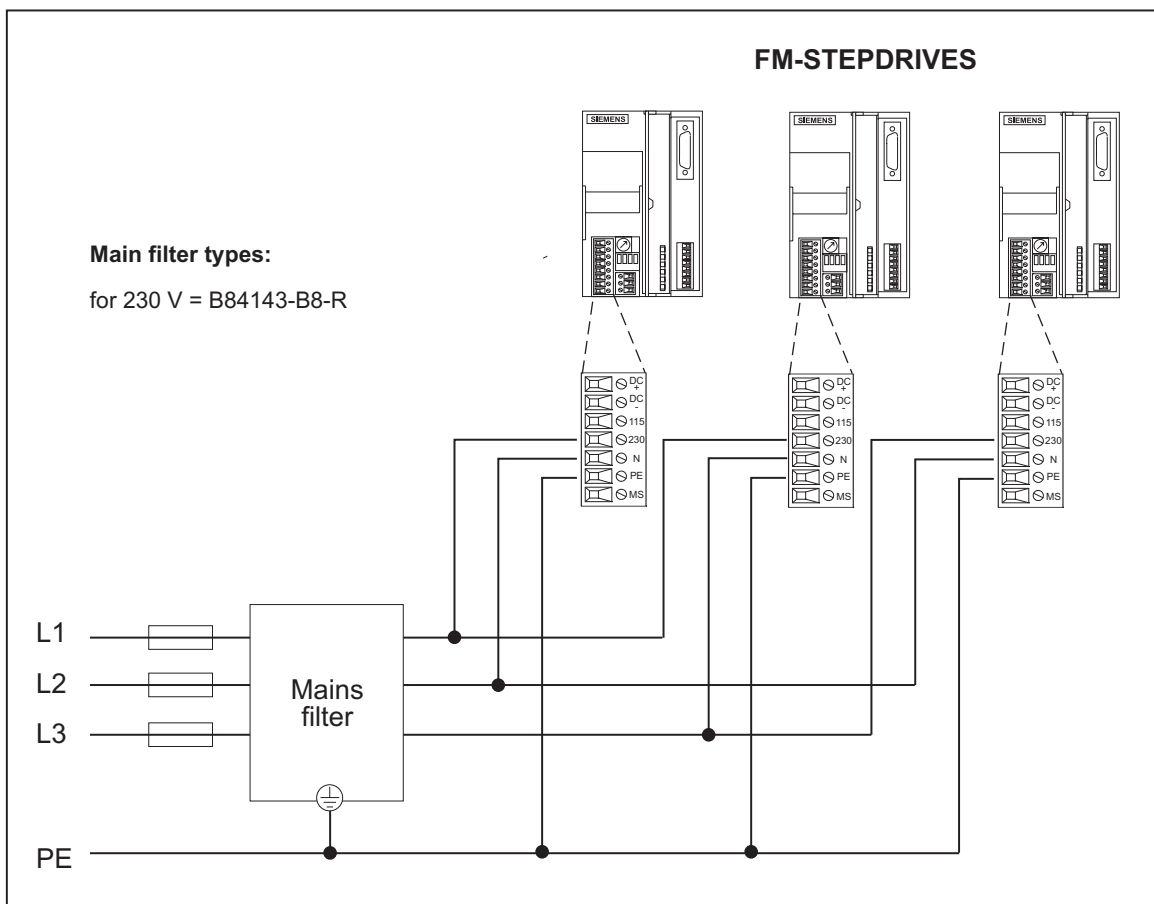

Figure 6-8 Multi-axis wiring with a three-phase mains connection (230 V between phases, without neutral)

---

**Note**

The intermediate circuit connections (DC+ and DC-) of the power controllers must not be interconnected!

---

**Note**

The mains connection cables must be shielded on both ends.

---



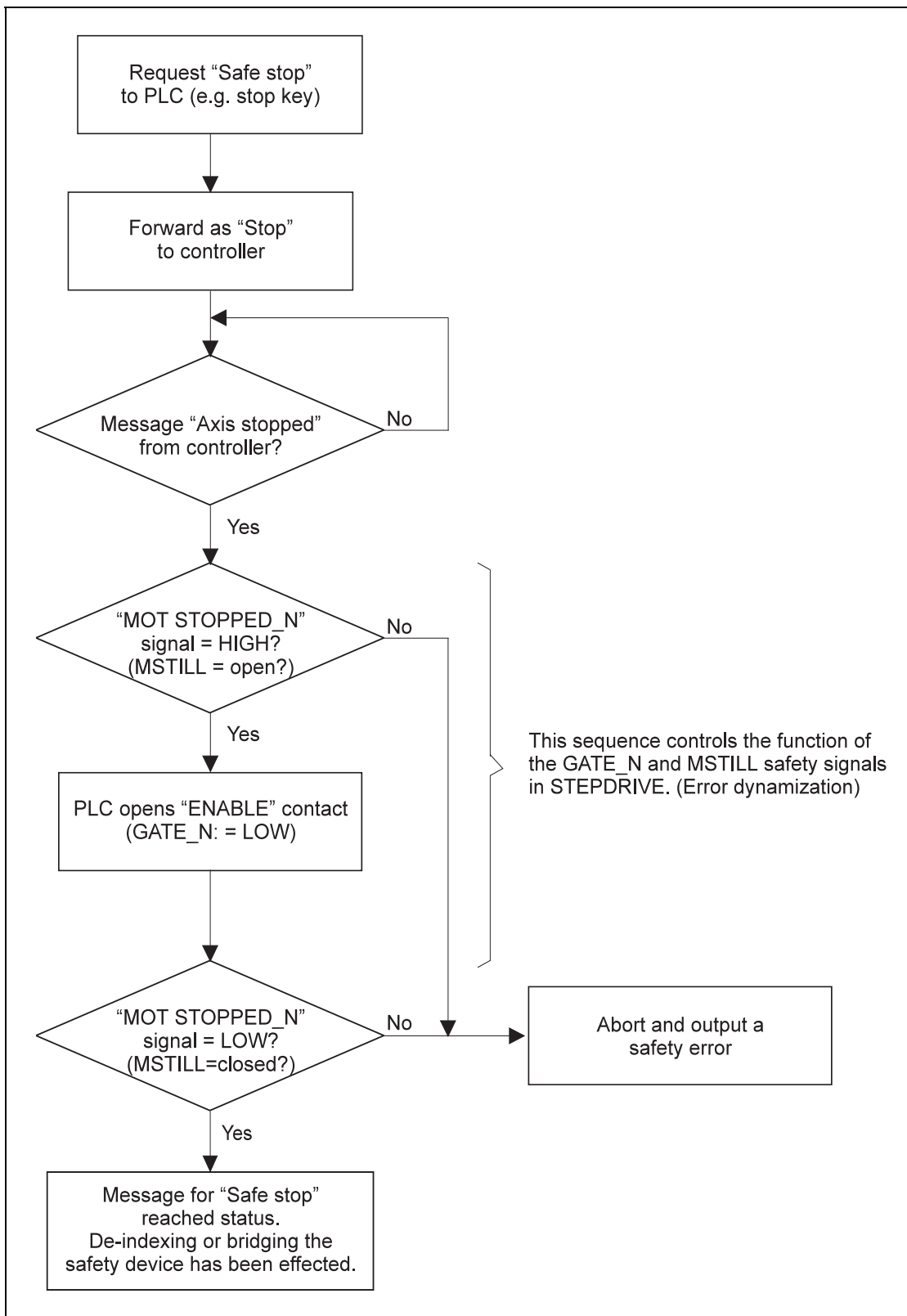

Figure 6-10 Sequence for obtaining the "Safe stop" status, programming example

## 6.6 Accessories

Accessories	Order number	Ordering information
Mains filter for one axis with single-phase power supply	for 115 V = B84142-B8-R for 230 V = B84113-C-B60	SIEMENS component service catalogue
Mains filter for several axes: For single-phase mains connection for 2 axes For single-phase mains connection for 3 axes For three-phase mains connection with neutral  For three-phase mains connector without neutral	for 115 V = B84142-B16-R for 230 V = B84142-B16-R for 115 V = B84299-K55 for 230 V = B84299-K53 for 230 V = B84143-B8-R	
Motor cable (non-terminated): Length 10 m Length 20 m Length 50 m	6FX5008-5AA00-1BA0 6FX5008-5AA00-1CA0 6FX5008-5AA00-1FA0	
Cable for pulse interface: For FM-353 (terminated, max. length 35 m)  For FM-NC/FM357 (FM-STEPDRIVE end non-terminated, max. length 35 m)	6FX2002-3AC02-1xx0  6FX2002-3AD02-1xx0	SIEMENS automation systems catalogue: NC60.1 or ST70, or for NCZ accessories
External back-up fuse: e.g. line circuit breaker 16 A with C characteristic 32 A with C characteristic	5SX2 116-7 5SX2 132-7	SIEMENS catalogue of circuit breaker and fuse systems

# Setup

# 7

After mounting and wiring, and with the mains voltage disconnected, make the following adjustments on the power controller:



**Caution**

The settings may only be made with the power supply disconnected.

1. Set the motor phase current on the selector switch

**Note**

For the relationship between phase current and ambient temperature, see chapter 3.3.

Position	0	1	2	3	4	5	6	7
Current [A]	1.7	2.0	2.4	2.7	3.1	3.4	3.7	4.1
Position	8	9	A	B	C	D	E	F
Current [A]	4.4	4.8	5.1	5.4	5.8	6.1	6.5	6.8



Recommended switch positions for motors:

SIMOSTEP	1FL3041	1FL3042	1FL3043	1FL3061	1FL3062
Position	0	1	2	7	9



**Warning**

Higher phase current settings than those specified above are not permitted since they may cause motor overheating. Lower phase current settings are admissible, however, they will result in a lower motor torque

2. Set the number of steps and the current reduction at standstill (to 60% after 100ms)

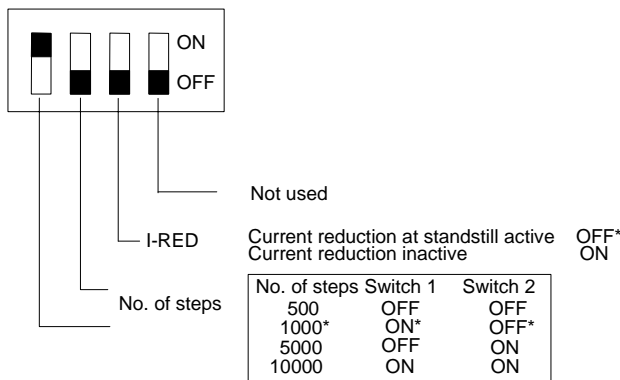

\* Default

3. Connect the mains voltage and the 24 V supply of the signal interface.
4. Activate the ENABLE input of the pulse interface or the ENABLE\_N input of the signal interface.

When the power controller operates properly, the LED RDY lights and the READY1\_N and READY2 outputs indicate readiness.

5. Activate the GATE\_N input. The GTE LED lights
6. Clock pulses can now be supplied to the PULSE input. With each clock pulse, the motor performs one step.



# Status indicators and troubleshooting

# 8



**Danger**

If a malfunction occurs, the motor is deenergized and the power controller indicates not ready status (LED RDY goes out). The READY1\_N and READY2 outputs have high resistance.  
 A motor does not have any holding torque when deenergized. This may cause undesirable effects.

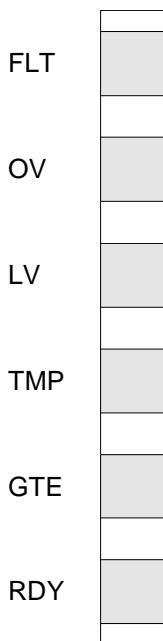

Indication	Cause	Rectification
FLT (FAULT) lights	Short-circuit between motor phases	1. Switch off mains voltage. 2. Check motor wiring; replace motor if necessary. 3. Switch on mains voltage.
OV (OVER-VOLT) lights	Overvoltage or motor's feedback energy too great	Check mains voltage and mains connection. Reduce feedback energy of the motor or dissipate the feedback energy via the intermediate circuit connection.
LV (LOW-VOLT) lights	Undervoltage	1. Check mains voltage and mains connection. 2. Adjust the voltage.
TMP (TEMP) lights	Overtemperature	1. Ensure sufficient air supply, or reduce ambient temperature. 2. After cooling down: Switch mains voltage or ENABLE signal off and on again.
GTE (GATE_N) not lighting	GATE input not activated motor not moving	Activate GATE_N input.
RDY (READY) lights	Unit is ready for operation.	-
OV (OVER-VOLT) and LV (LOW-VOLT) light	ENABLE input is inactive.	Activate ENABLE input.
OV (OVER-VOLT), LV (LOW-VOLT), FLT (FAULT) and TMP (TEMP) light	Excessive clock frequency on PULSE input or high-frequency interference	1. Check clock frequency. 2. Switch mains voltage or ENABLE signal off and on again.

**Other malfunctions  
which are not  
indicated**

<b>Malfunction</b>	<b>Cause</b>	<b>Rectification</b>
None of the LEDs light	Mains voltage not available	Check mains voltage and mains connection wiring.
Motor does not rotate and does not have a holding torque	PWM signal input active	Set PWM input to inactive.
	Motor line(s) interrupted	With the mains voltage disconnected, check the motor wiring.
Motor does not rotate but does have a holding torque	No clock signal present on PULSE input	Supply clock signal to PULSE input.
Motor turns in incorrect direction	Motor phases interchanged	Connect the motor phases properly.
	DIR signal input set incorrectly	Invert signal on DIR input.
Motor torque is too low (motor slips)	Motor phase current set too low	Set phase current correctly.
	Acceleration ramp too steep	Reduce acceleration ramp on control unit.
	The drive is mechanically blocked	Eliminate mechanical blocking.
	Connected motor's rating is insufficient	Connect a more powerful motor.

**Caution**

Before replacing the power controller, check motor and wiring for a ground fault!



# **SIMOSTEP specifications**

# **9**

Specifications		SIMOSTEP				
		1FL3041	1FL3042	1FL3043	1FL3061	1FL3062
Max. torque	$M_m$ [Ncm]	200	400	600	1000	1500
Holding torque	$M_H$ [Ncm]	226	452	678	1130	1695
Rotor inertia	$J_R$ [kgcm <sup>2</sup> ]	1.1	2.2	3.3	10.5	16
Number of steps	z	500 / 1000 / 5000 / 10000				
Step angle	$\alpha$ [°]	0.72 / 0.36 / 0.072 / 0.036				
Systematic angle tolerance per step <sup>1)</sup>	$\Delta\alpha_s$ [ ' ]	±6				
Max. starting frequency <sup>1)</sup>	$f_{Aom}$ [kHz]	5.3			4.3	
Nominal current/supply line	$I_w$ [A]	1.75	2.0	2.25	4.1	4.75
Resistance/coil	$R_w$ [Ω]	6.5	5.8	6.5	1.8	1.9
Current rise time constant	$\tau$ [ms]	~7	~9	~10	~22	~22
Admissible dynamic shaft load <sup>2)</sup>	axial [N]	~60	~60	~60	~60	~60
	radial [N]	~100	~100	~110	~300	~300
Weight (approx.)	G [kg]	2.05	3.1	4.2	8.0	11
Motor voltage	U [V]	325	325	325	325	325

<sup>1)</sup> Measured at 1000 steps/revolution

<sup>2)</sup> Applied at half-way from shaft exit (motor flange).

### Characteristics common to all type sizes

- Test voltage acc. to VDE 0530
- Degree of protection IP41 at front shaft exit
- Degree of protection IP56 on terminal box
- Insulation class F
- Shaft runout and axial runout acc. to DIN 42955 N
- Ambient temperature, operating -20°C to +40°C\*
- Transport and storage temperature -40°C to +70°C

\* Only if flange-mounting is correct

**Dimension drawings for motors without brake**

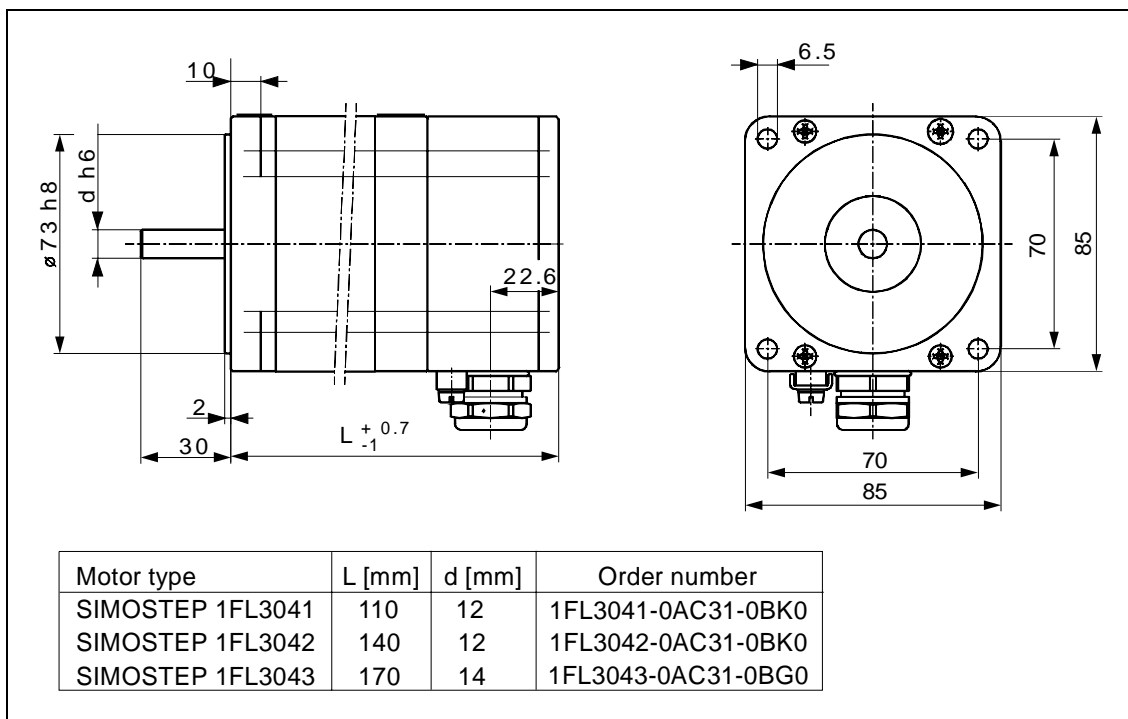

Figure 9-1 SIMOSTEP 1FL3041, 1FL3042, 1FL3043 dimension drawings (for motors without brake)

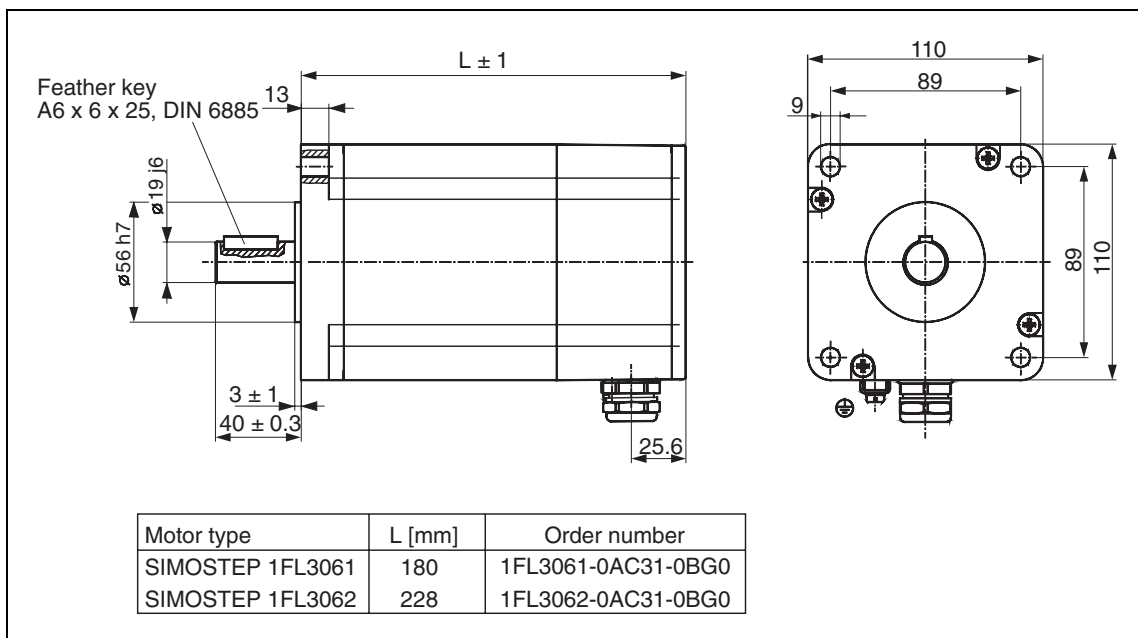

Figure 9-2 SIMOSTEP 1FL3061, 1FL3062 dimension drawings (for motors without brake)

**Dimension drawings for motors with brake**

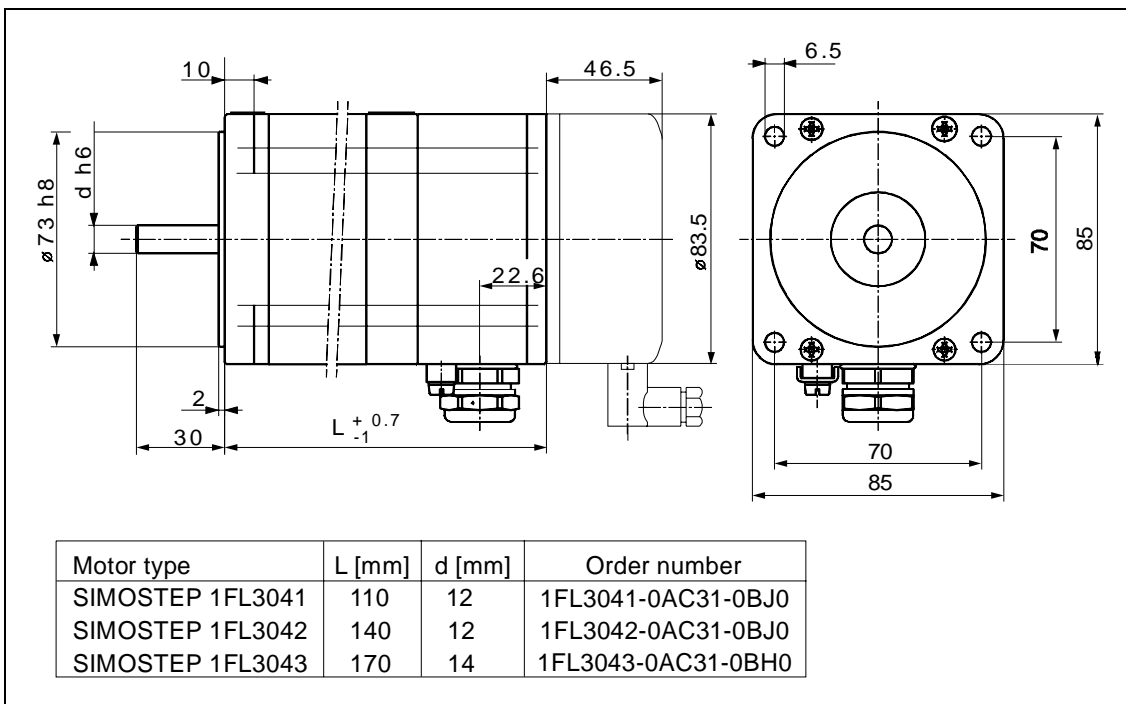

Figure 9-3 SIMOSTEP 1FL3041, 1FL3042, 1FL3043 dimension drawings (for motors with brake)

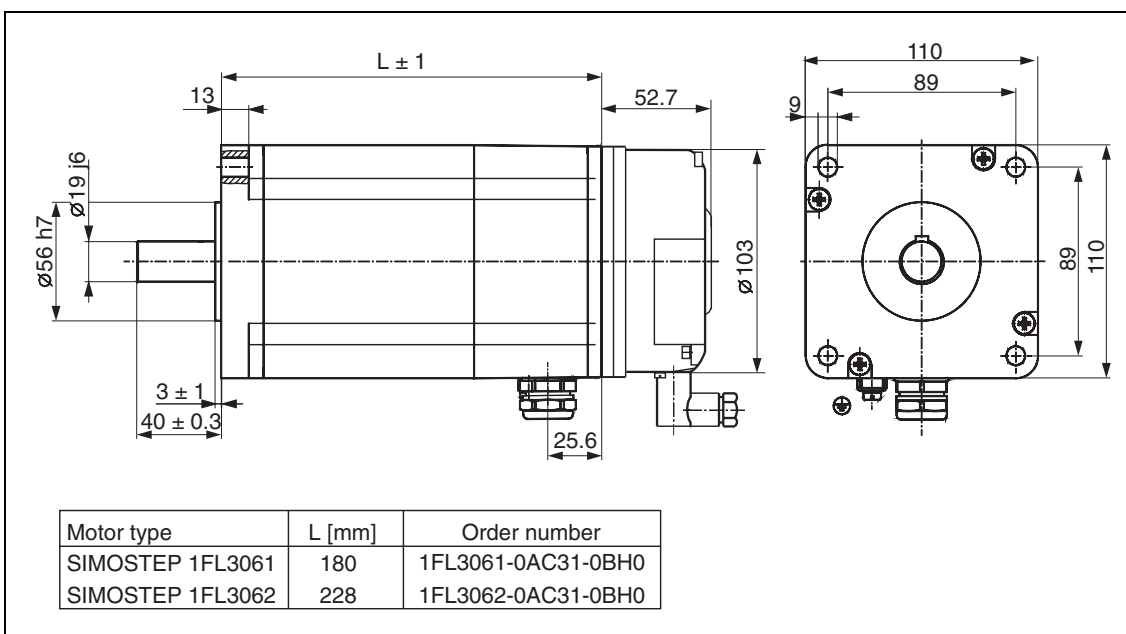

Figure 9-4 SIMOSTEP 1FL3061, 1FL3062 dimension drawings (for motors with brake)



**3-phase stepping motors with holding brake**

The holding brakes are used to hold the motor in position when the motor current is switched off. In cases of emergency, e.g. power failure or EMERGENCY OFF, they stop the drive, thus contributing to the safety of the system. The brakes are required for applications in which gravity forces play a role, e.g. Z-axes in handling systems.



**Caution**

In order to ensure reliable functioning of the Z axes with holding brakes, the static loading torque should not exceed a maximum of 25% of the motor holding torque.

**Function**

The holding brakes are designed as electromagnetic spring pressure brakes. In order to disengage the brake, it must be electrically excited when the motor current is switched on. To avoid high temperature of the brake, the current for the brake is reduced to holding voltage when the brake is still disengaged (see figure 9-5).

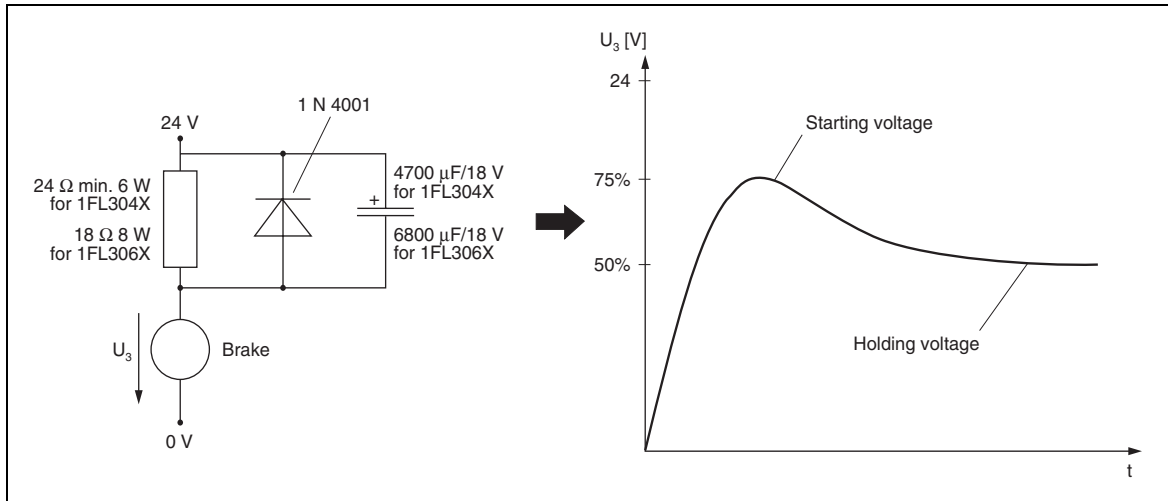
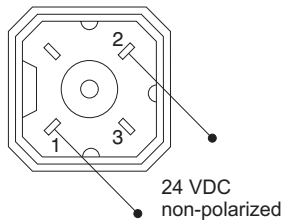

Figure 9-5 Example of a circuit to reduce dissipation of the holding brake

**Terminal assignment**



**Performance data of holding brake**

Specifications	Motor-size	
	90	110
Nominal voltage (power supply via pin 1 and 2)	24 V	24 V
Holding torque	6 Nm	16 Nm
Power consumption	24 W	32 W
Moment of inertia	0,2 kgcm <sup>2</sup>	0,35 kgcm <sup>2</sup>
<b>Switching times</b>		
On (disengage brake)	35 ms	65 ms
Off (engage brake)	15 ms	15 ms

**Torque characteristics**

The torque of a motor depends on the speed of the rotor and on the motor phase current set on the power controller.

For the torque characteristic curve measurements, 1000 steps per revolution and the appropriate nominal motor current were set on the FM-STEPDRIVE power controller \*. The characteristic curves were measured at the nominal values of the supply voltages 115 V/50 Hz and 230 V/50 Hz.

The following formula reflects the relationship between the control frequency  $f_s$ , the number of steps  $z$  and the speed  $n$  of the motor:

$$n = 1/z \cdot f_s \cdot 60 \text{ r.p.m.}$$

The following characteristics are illustrated in each case:

- ① Slew curve
- ② Start/stop curve (start frequency as a function of the load torque)
- ③ Load inertia curve

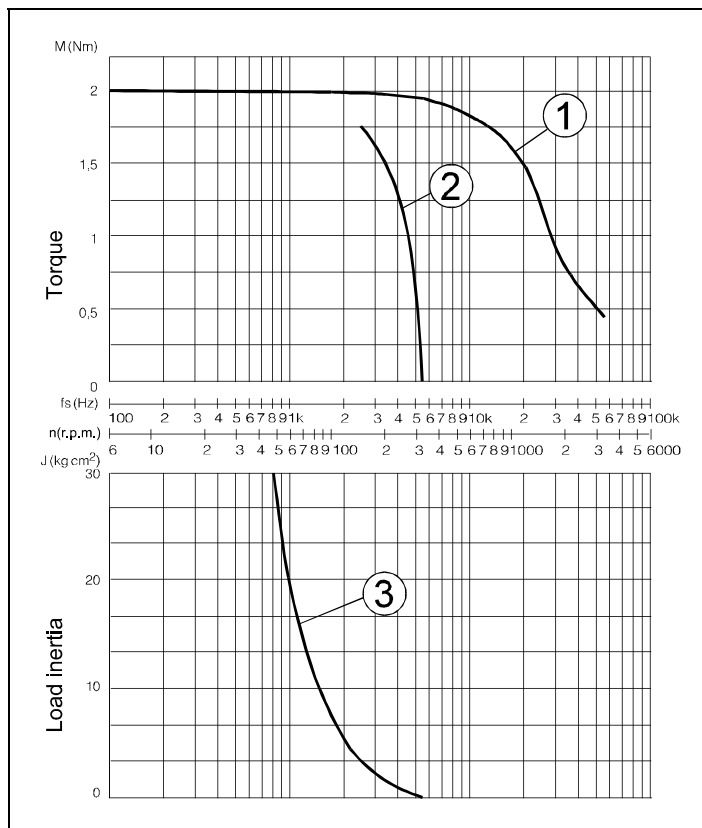

Figure 9-6 SIMOSTEP 1FL3041 torque characteristics

\* For 500/5000/10000 numbers of steps, the  $f_s$  scale must be multiplied with the factors 0.5/5/10, respectively.

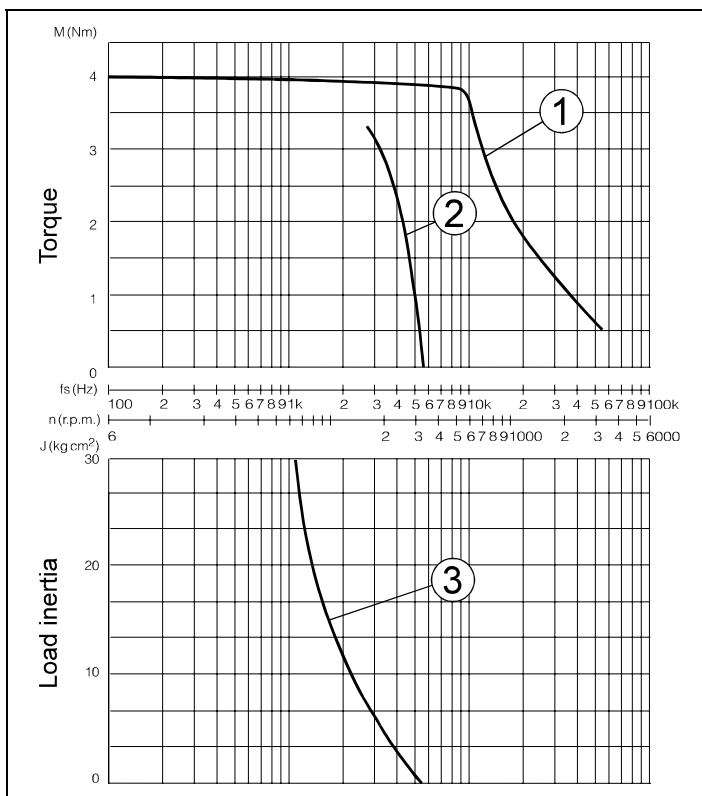

Figure 9-7 SIMOSTEP 1FL3042 torque characteristics

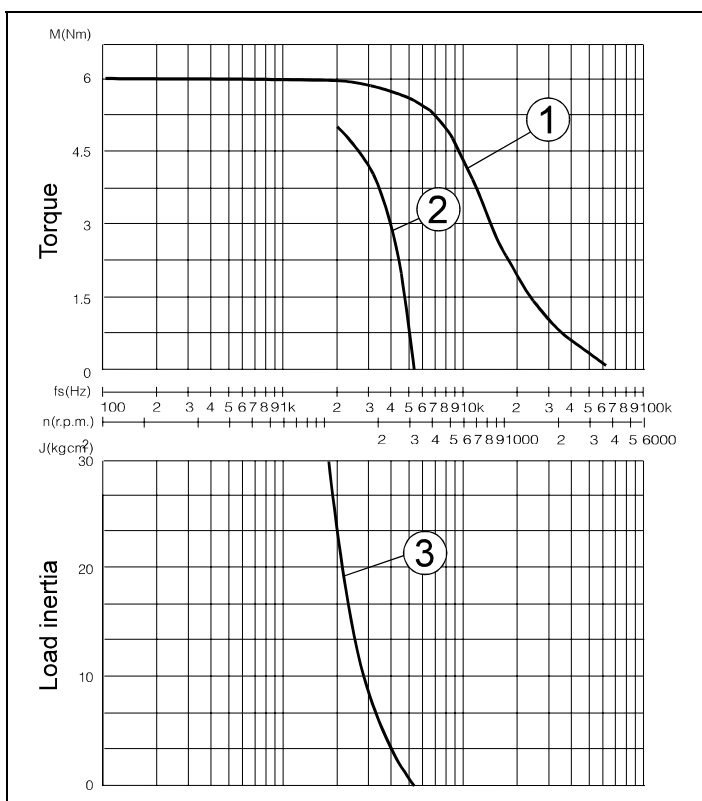

Figure 9-8 SIMOSTEP 1FL3043 torque characteristics

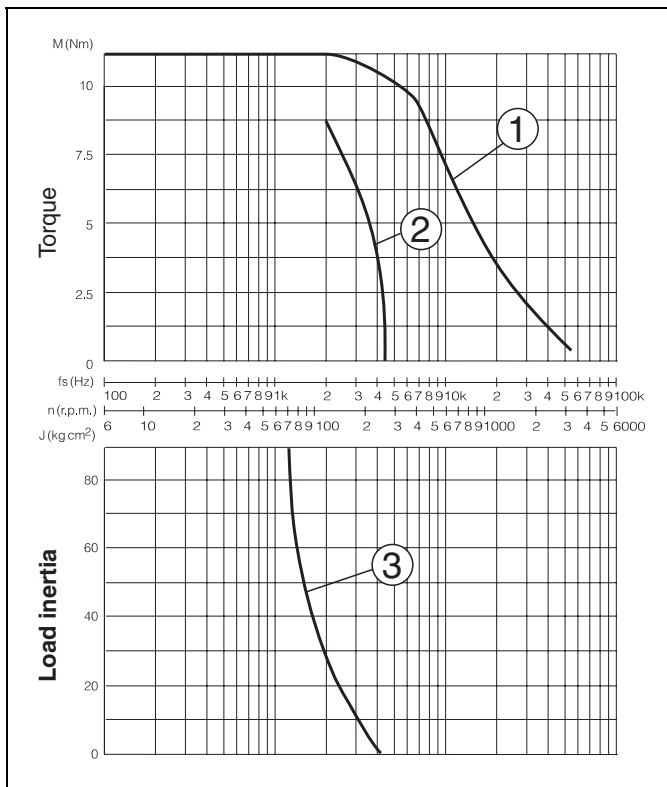

Figure 9-9 SIMOSTEP 1FL3061 torque characteristics

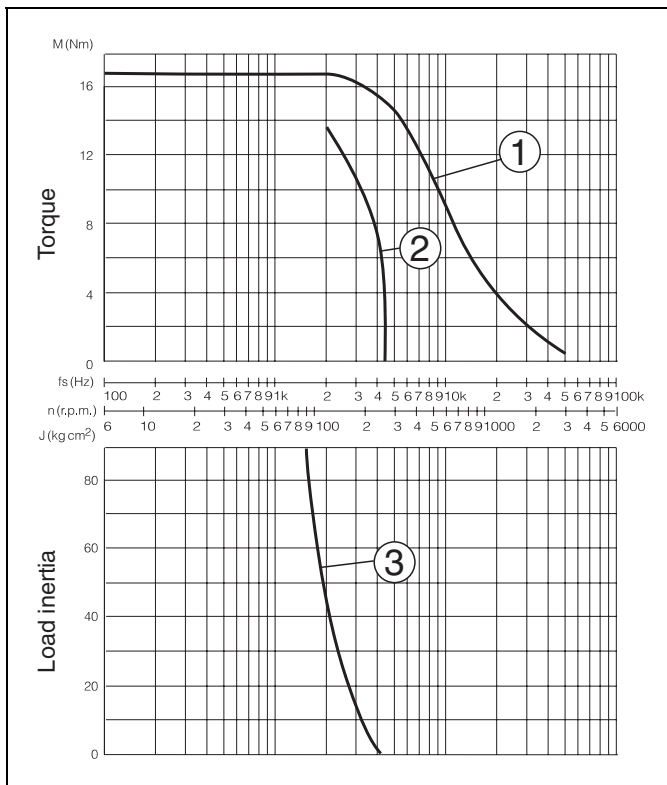

Figure 9-10 SIMOSTEP 1FL3062 torque characteristics

# 10

## Stepping motor parameters and characteristics

10.1	Basic concepts.....	10-2
10.2	Torque characteristics .....	10-3

A number of certain parameters and characteristics must be known for examining and selecting a stepping motor. Each stepping motor has its specific properties in conjunction with the power controller used; these properties are represented by characteristic curves. To facilitate an understanding of their contents and meaning, the essential parameters and the usage of the characteristics are explained here.

## 10.1 Basic concepts

<b>Step angle</b>	A step refers to a motor shaft rotation by the step angle ; the step is initiated by a control pulse.
<b>Number of steps</b>	The number of steps specifies the number of steps the rotor performs per revolution. The number of steps can be adjusted for a 3-phase stepping motor.
<b>Holding torque</b>	The rotor is held in each step position due to the DC excitation of the coils unless its holding torque $M_H$ is exceeded on the motor shaft.
<b>Systematic angle tolerance</b>	The systematic angle tolerance per step $\Delta\alpha_s$ specifies the maximum number of angular minutes a step may deviate from the nominal step angle.
<b>Control and stepping frequency</b>	With a continuous sequence of control pulses at a control frequency $f_s$ , the motor shaft will also execute a sequence of steps at the (same) stepping frequency $f_z$ .
<b>Speed</b>	<p>From a specific control frequency onwards (depending on motor type and mechanical load) the step-by-step movement of the motor shaft verges into a continuous rotary movement. The following then applies for the speed <math>n</math> of the motor:</p> $n = \alpha/360^\circ \cdot f_z \cdot 60 \text{ r.p.m. } (f_z[\text{Hz}])$
<b>Torques</b>	<p>If the rotating motor shaft is subjected to a load torque <math>M_L</math>, the motor will continue to follow the control frequency synchronously unless the load torque exceeds a certain limit, i.e. the maximum torque at maximum slew stepping rate <math>M_{Bm}</math>.</p> <p>In this case, the rotor cannot follow the control frequency any more, and a step "loss" will occur, where control frequency and stepping frequency are no longer identical.</p> <p>Such a situation can be avoided by selecting the correct motor and by controlling it correctly</p>

## 10.2 Torque characteristics

The maximum torque at maximum slew stepping rate  $M_{Bm}$  of a stepping motor depends on its type size, on the type of electrical control and, in particular, on the stepping frequency. This relationship is specified as a characteristic curve for each stepping motor system.

The maximum torque at maximum slew stepping rate  $M_{Bm}$  can be output by the motor at low stepping frequencies; the higher the stepping frequency, the lower the maximum torque at maximum slew stepping rate.

The operating range of the motor given by the maximum torque at maximum slew stepping rate is divided into the starting range and the acceleration range. In the starting range, the motor is able to follow a suddenly activated or interrupted control frequency without a stepping error; in the acceleration range, the control frequency may only be changed gradually (frequency ramp) in order to prevent the motor from losing synchronicity.

The starting range is limited by the characteristic curve of the starting limit frequency  $f_{Am}$  (start/stop characteristic): Without load, the motor can start at the maximum starting frequency  $f_{Aom}$ ; with a load, the starting frequency is reduced.

### Load inertia

The size of the starting range also depends on the load inertia  $J_L$  exerted by the load on the motor shaft. With  $J_L$  increasing, the start/stop characteristic shifts towards lower frequencies. The start/stop characteristic shows the maximum starting frequency  $f_{Aom}$  as a function of the load inertia  $J_L$ . If a load inertia and a load torque are present at the same time, the starting limit frequency  $f_{Am}$  is determined by moving the start/stop characteristic in the torque diagram in parallel to the left until the maximum starting frequency  $f_{Aom}$  corresponds to the one determined in the  $J_L$  diagram (see figure).

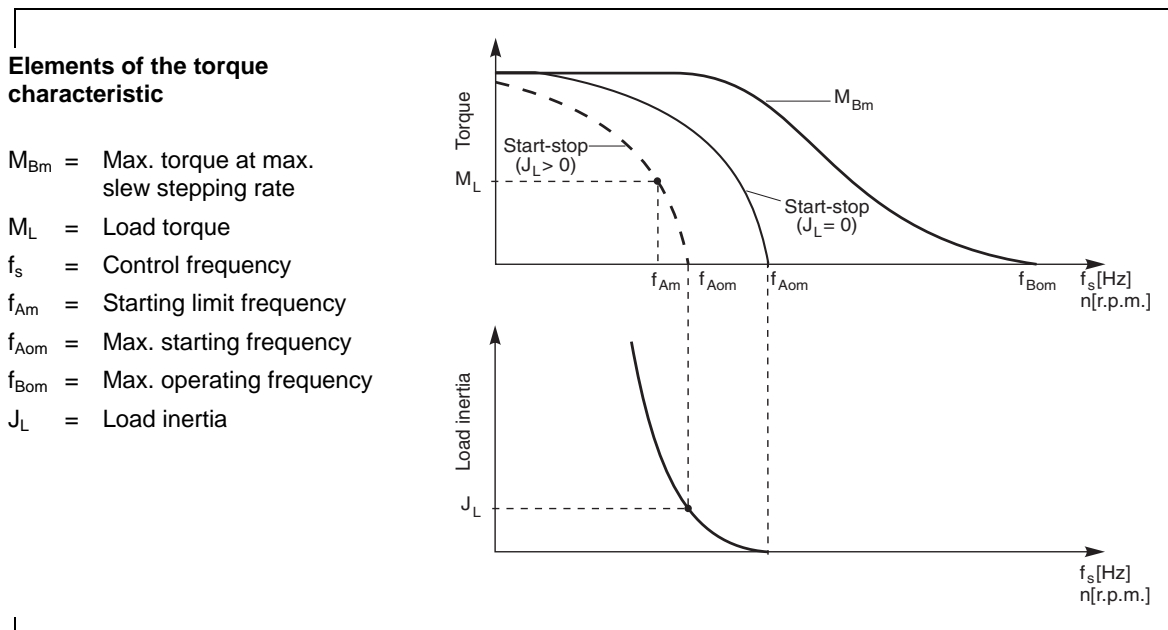

Figure 10-1 Elements of the torque characteristic





Siemens AG

A&D MC BMS  
P.O. Box 31 80

D-91050 Erlangen  
Federal Republic of Germany

**Suggestions**

**Corrections**

For Publication/Manual:

SIMATIC

FM-STEPDRIVE/SIMOSTEP

Power Controller and 3-Phase Stepping  
Motors

Supplier Documentation

Functional description

Order No.: 6SN1197-0AA70-0YP5

Edition: 02.05

Should you come across any printing errors  
when reading this publication, please notify us  
on this sheet. Suggestions for improvement  
are also welcome.

From:

Name:

Address of your company/department

Street etc.: \_\_\_\_\_

ZIP: \_\_\_\_\_ City: \_\_\_\_\_

Phone: \_\_\_\_\_ / \_\_\_\_\_

Fax: \_\_\_\_\_ / \_\_\_\_\_





**Siemens AG**

Automation and Drives

Motion Control Systems

Postfach 3180, D – 91050 Erlangen

Bundesrepublik Deutschland

[www.siemens.com/motioncontrol](http://www.siemens.com/motioncontrol)

© Siemens AG 2005  
Subject to change without prior notice  
Order No.: 6SN1197-0AA70-0YP5

Printed in the Federal Republic of Germany