

ac-drives

Three-phase induction motor - AH 225
A5E00264369A
Type 1PH722.

SIEMENS

ac drives Three-phase servomotor

Operating Instructions

Safety information

1

Description

2

Installation / Assembly

3

Startup

4

Operation

5

Faults

6

Maintenance

7

Spare parts

8

Supplementary instructions
(options, third-party
suppliers)

9

Safety Guidelines

This manual contains notices which you should observe to ensure your own personal safety as well as to avoid property damage. The notices referring to your personal safety are highlighted in the manual by a safety alert symbol, notices referring to property damage only have no safety alert symbol.



Danger

indicates an imminently hazardous situation which, if not avoided, will result in death or serious injury.



Warning

indicates a potentially hazardous situation which, if not avoided, could result in death or serious injury.



Caution

used with the safety alert symbol indicates a potentially hazardous situation which, if not avoided, may result in minor or moderate injury.

Caution

used without safety alert symbol indicates a potentially hazardous situation which, if not avoided, may result in property damage.

Notice

used without the safety alert symbol indicates a potential situation which, if not avoided, may result in an undesirable result or state.

When several danger levels apply, the notices of the highest level (lower number) are always displayed. If a notice refers to personal damages with the safety alert symbol, then another notice may be added warning of property damage.

Qualified Personnel

The device/system may only be set up and operated in conjunction with this documentation. Only qualified personnel should be allowed to install and work on the equipment. Qualified persons are defined as persons who are authorized to commission, to earth, and to tag circuits, equipment and systems in accordance with established safety practices and standards.

Intended Use

Please note the following:



Warning

This device and its components may only be used for the applications described in the catalog or technical description, and only in connection with devices or components from other manufacturers approved or recommended by Siemens.

This product can only function correctly and safely if it is transported, stored, set up and installed correctly, and operated and maintained as recommended.

Trademarks

All designations marked with ® are registered trademarks of Siemens AG. Other designations in this documentation might be trademarks which, if used by third parties for their purposes, might infringe upon the rights of the proprietors.

Copyright Siemens AG, . All rights reserved

Reproduction, transmission or use of this document or its contents is not permitted without express written authority. Offenders will be liable for damages. All rights, including rights created by patent grant or registration of a utility model or design, are reserved.

Disclaimer of Liability

We have checked the contents of this manual for agreement with the hardware and software described. Since deviations cannot be precluded entirely, we cannot guarantee full agreement. However, the data in the manual are reviewed regularly, and any necessary corrections will be included in subsequent editions. Suggestions for improvement are welcomed.

Siemens AG
Automation and Drives Group
P.O. Box 4848, D-90327 Nuremberg (Germany)

Siemens AG 2004
Technical data subject to change

Table of contents

1	Safety information	1-1
1.1	Definitions, warning information.....	1-1
1.2	Safety and application information.....	1-2
1.3	EC Declaration by the manufacturer.....	1-4
1.4	EC Declaration of Conformity	1-5
2	Description	2-1
2.1	Applications.....	2-1
2.2	Siemens Service Center	2-1
2.3	Scope of delivery	2-1
2.4	Nameplate.....	2-2
2.5	Design	2-3
2.5.1	Cooling	2-3
2.5.2	Drive.....	2-4
2.5.3	Types of construction.....	2-5
2.5.4	Regulations	2-6
2.5.5	Degree of protection	2-6
3	Installation / Assembly	3-1
3.1	Transport, storage.....	3-1
3.2	Installation.....	3-2
3.3	Mounting	3-4
3.4	Connecting the stator winding.....	3-5
3.5	Connecting the ground conductor.....	3-9
3.6	Connecting the fan.....	3-10
3.7	Connecting the speed sensor	3-13
3.8	Connecting the temperature sensor	3-14
4	Startup	4-1
4.1	Preparations.....	4-1
4.2	Measures to be performed prior to commissioning.....	4-2
4.3	Energizing	4-4
5	Operation	5-1
5.1	Operation	5-1
5.2	Stoppages.....	5-2
5.3	De-energizing.....	5-2
6	Faults	6-1

6.1	Fault diagnosis table	6-1
7	Maintenance	7-1
7.1	Maintenance	7-1
7.1.1	Maintenance instructions	7-1
7.1.2	Maintenance intervals	7-2
7.1.3	Bearings	7-3
7.1.4	Lubrication (optional).....	7-3
7.1.5	Cleaning	7-5
7.2	Inspection	7-6
7.2.1	General inspection specifications	7-6
7.2.2	Initial inspection.....	7-7
7.2.3	Main service	7-7
7.3	Repair	7-8
7.3.1	Instructions for repair	7-8
7.3.2	Dismantling	7-9
7.3.3	Re-assembly	7-11
7.3.4	Bolted connections.....	7-14
8	Spare parts	8-1
8.1	Orders for spare parts	8-1
8.2	Spare parts 1PH7.....	8-1
9	Supplementary instructions (options, third-party suppliers).....	9-1

Tables

Table 2-1	Motor nameplate - Technical Data:.....	2-2
Table 3-1	Weights of standard versions (IM B3).....	3-1
Table 3-2	Pressure drop in motors with pipe connection	3-3
Table 3-3	Terminal box assignment, max. connectable cross-section per terminal	3-6
Table 3-4	Tightening torque for the fixing screws on the lid	3-9
Table 6-1	Diagnosis table for mechanical faults	6-1
Table 6-2	Diagnosis table for electrical faults	6-2
Table 7-1	Service period intervals.....	7-3
Table 7-2	Rolling-contact bearing greases	7-4

1 Safety information

1.1 Definitions, warning information

Qualified persons

Only qualified persons are authorized to commission and operate this product in conjunction with this documentation. Qualified persons as far as the safety instructions given in this documentation are concerned are those who have the necessary authorization to commission, ground and identify equipment, systems and circuits in accordance with the relevant safety standards.

Safety Guidelines

This documentation contains instructions which must be followed closely in order to ensure personal safety and to avoid damage to the equipment and machines. Personal safety instructions are highlighted in the manual by a warning triangle, while damage instructions are not, and are marked as follows according to the level of danger:



Danger

Danger means that death, grievous injury or extensive damage to property will occur if the appropriate precautions are not taken.



Warning

Warning means that death, grievous injury or extensive damage to property may occur if the appropriate precautions are not taken.



Caution

Caution with a warning triangle means that minor personal injury may occur if the appropriate precautions are not taken.

Caution

Caution without a warning triangle means that damage to property may occur if the appropriate precautions are not taken.

Notice

Attention means that an undesirable result or state might occur if the relevant instructions are not followed.

Note

Note indicates important information concerning the product, its use or the corresponding section of the documentation which must be given special attention and is recommended to be adhered to because of the potential benefits.

Compliance with intended use

Please pay close attention to the following:



Warning

The electrical equipment contains items that are at a dangerous voltage.

Before any work may be carried out, it must be ensured that the equipment has been set to zero potential.

Only qualified persons may work with this equipment.

These persons must be familiar with all instructions and measures in this documentation that are relevant for safety.

Faultless and safe operation of this equipment requires appropriate transport, storage, installation and assembly as well as careful operation and maintenance.

The equipment may only be used for single purpose applications explicitly described in the catalog and in the technical description and it may only be used along with third-party devices and components recommended by Siemens.

Failing to adhere to these instructions may result in severe injury and/or damage to property.

National safety regulations must be closely observed.

[ID: 1]

1.2 Safety and application information

The safe use of electric motors



Danger

These electric motors are designed for use in industrial power systems. Rotating or live and uninsulated parts pose a danger.

There is consequently a risk of fatal or severe personal injury or substantial damage to property if the necessary covers are removed without authorization or if the equipment is handled improperly, operated incorrectly or maintained inadequately.

If the motors are used outside industrial areas, the installation site must be safeguarded against unauthorized access by means of suitable protection facilities (e.g. fencing) and appropriate warning signs.

The persons responsible for the safety of the system are under an obligation to ensure that:

- the basic planning work for the system and all work relating to transportation, assembly, installation, commissioning, maintenance and repairs are carried out by qualified persons and checked by responsible, suitably skilled persons.
- these instructions and the motor documentation are made available at all times while work is in progress.
- the technical data and specifications relating to the permissible installation, connection, ambient and operating conditions are taken into account at all times.
- the system-specific erection and safety regulations are observed and personal protective gear is used.
- work on these motors, or in the vicinity of these motors, by unqualified persons is prohibited.

These instructions therefore only contain the information which is necessary for the motors to be used by qualified persons in accordance with their intended purpose.

The instructions and the motor documentation are available in the languages specified in the supply contracts.

Note

We recommend engaging the support and services of your local Siemens service center for all planning, installation, commissioning and maintenance work.

[ID: 2]

1.3 EC Declaration by the manufacturer

SIEMENS

EU Supplier's Declaration

(in accordance with Art. 4 Para. 2 of EU Directive 98/37/EU)

No. A1A 3435.H002 DE / 05.01

Manufacturer: Siemens Aktiengesellschaft
Automation and Drives Group
Large Drives Division
Industry Subdivision

Address: Vogelweiherstraße 1 - 15
90441 Nuremberg
Federal Republic of Germany

Product designation: **Three-phase asynchronous machine 1PH7...
Shaft height 18 to 28.**

The designated product is only intended for installation in another machine.
Start-up is forbidden until it has been confirmed that the final product conforms with Directive 98/37/EU.

We confirm that the products designated above conform with the following standards:

- EN 60034-1
- EN 60034-5
- EN 60034-6
- EN 60034-9
- EN 60204-1, Section 16

Siemens Aktiengesellschaft

Nuremberg,*28/2/07*..... (date)

.....*J. Amedick*.....
A&D LD I, Jürgen Amedick
Head of Industry Subdivision

.....*K. Hermes*.....
A&D LD I BA, Klaus Hermes
Business Administration Head of Industry
Subdivision

This declaration does not constitute a guarantee of product characteristics in the sense of product liability.
The safety notes in the product documents must be complied with.

1.4 EC Declaration of Conformity

SIEMENS

EU Declaration of Conformity

No. A1A 3435.K005 DE / 05.01

Manufacturer: Siemens Aktiengesellschaft
Automation and Drives Group
Large Drives Division
Industry Subdivision

Address: Vogelweiherstraße 1 - 15
90441 Nuremberg
Federal Republic of Germany

Product designation: **Three-phase asynchronous machine 1PH7...
Shaft height 18 to 28.**

The designated product agrees with the stipulations of the following European directive:

Directive 73/23/EEC Directive of the council for harmonization of the legal regulations of member states with regard to electrical equipment for use within certain voltage limits, altered by RL 93/68/EEG of the council

Agreement with this Directive is verified by conformance with the following standards:

Harmonized European standards: EN 60 034-1
EN 60 034-5
EN 60 034-6
EN 60 034-9
EN 60 204-1

Safety notes and operating instructions are also to be adhered to.

CE marking first attached: 1996

Siemens Aktiengesellschaft

Nuremberg,28/12/03..... (date)

.....J. V. Amedick.....
A&D LD I, Jürgen Amedick
Head of Industry Subdivision

.....K. Hermes.....
A&D LD I BA, Klaus Hermes
Business Administration Head of Industry
Subdivision

This declaration certifies agreement with the directives referred to but does not constitute a guarantee of product characteristics in the sense of product liability.

2 Description

2.1 Applications

Overview

Three-phase motors of the 1PH7 series are used as industrial drives. They have been designed for a wide range of applications in the fields of drive engineering and power conversion.

They stand out thanks to their high power density, their ruggedness, long lifetime and reliability.

[ID: 301]

2.2 Siemens Service Center

Contact for further information

Details about the design of the three-phase motor supplied and about the permissible operating conditions are described in these Operating Instructions.

If you have any questions or suggestions, or if you require further information, please contact the SIEMENS Service Center:

Industry Help line (24-hour service): 0180 – 5050111

A&D Technical support: 0180 - 5050222

e-mail: adsupport@siemens.com

[ID: 302]

2.3 Scope of delivery

Checking the scope of delivery for completeness

The drive systems are put together on an individual basis. When you take receipt of the delivery, please check immediately whether the scope of the delivery matches up with the

accompanying documents. Siemens will not accept any warranty claims relating to items missing from the delivery that are submitted later.

Register a complaint about:

- any apparent transport damage with the delivery agent immediately.
- any apparent defects/missing components with the appropriate SIEMENS office immediately.

These Operating Instructions belong to the scope of delivery and must be kept where they can be easily accessed.

The nameplate enclosed as a loose item with the delivery is provided to enable the motor data to be located on or near the motor or installation.

[ID: 303]

2.4 Nameplate

Technical Data

The motor nameplate carries the technical data valid for the motor delivered.

SIEMENS		UL		UL		CE	
3~Mot. 1PH7 228-2NF23CJ0				NoN-R91129679010001/ 2004			
IM B3		IP 55		Th.Cl. F		Gew./WT. 870 kg	
V		A		kW		cosφ	
340 Y		350		160		0.82	
395 Y		342		179		0.81	
450 Y		332		196		0.79	
Hz		1/min		max		4500 1/min	
50,5		1500		58,8		1750	
67,1		2000		DIN EN / EC 60034-1		KTY84	
ENCODER_D01_2048_SR		MADE IN GERMANY D-90441 Nürnberg		DEW0244			

Figure 2-1 Example: Motor nameplate 1PH7

The motor nameplate carries the following technical data:

Table 2-1 Motor nameplate - Technical Data:

Item	Technical Data
1	Motor type: Three-phase servomotor
2	Type of construction
3	Degree of protection
4	Rated voltage [V] and winding connections

Item	Technical Data
5	Rated current [A]
6	Rated output [kW]
7	Standards and regulations
8	Code sensor type, temperature sensor KTY B4
9	ID no., serial number
10	Motor weight [kg]
11	Temperature class
12	Rated speed [rpm]
13	Rated frequency [Hz]
14	Power factor [cosφ]
15	Maximum speed [rpm]

[ID: 387]

2.5 Design

2.5.1 Cooling

Description

The three-phase motors of the 1PH7 series are externally ventilated, low-voltage induction motors with a squirrel-cage rotor and a separately driven fan unit mounted as standard. They are of an enclosed design, with a cooling circuit (cooling method IC06; DIN EN IEC 60034-6).

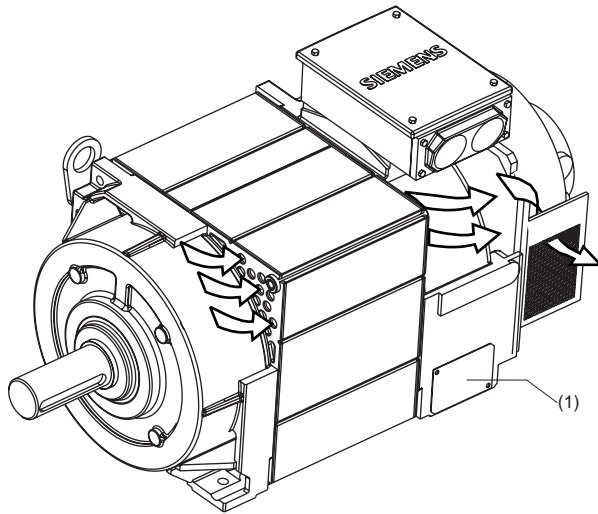

Figure 2-2 Cooling process for ventilating from the D-end to the N-end (basic type)
(1) Cover sheet

A KTY B4 temperature sensor is installed in the stator winding to monitor the winding.

Depending on the order, various additional devices, such as sensor systems can be installed or built on.

Notice

A minimum clearance of 100 mm from devices added on by the customer must be observed at the air intake opening and at the air outlet openings, in order to guarantee the necessary flow of cooling air.

Caution

Missing cover sheets can result in a considerably reduced cooling capacity and thus cause an inadmissible temperature rise within the motor.

Please ensure that the cover sheets are always mounted.

[ID: 311]

2.5.2 Drive

Description

The variable-speed, three-phase motors of the 1PH7 series are supplied with power by a frequency converter.

[ID: 313]

2.5.3 Types of construction

Further potential applications

The type of construction of the motor is stated on the rating plate.



Caution

During transport motors may only be hoisted in a position corresponding to their basic type of construction.

Basic type of construction acc. to rating plate	Type	Other applications in type of construction
IM B3	1PH7 224 to 1PH7 228	IM B6, IM B7, IM B8, IM V5, IM V6
IM B35 (1)	1PH7 224 to 1PH7 228	IM V36, IM V15

The max. admissible number of revolutions for flange-mounted construction types (IM B5, IM V1, IM V3) is restricted to 2500 rpm (see also "Planning Guide").

Note

For additional instructions and restrictions for types of construction that do not correspond to the basic type, please refer to the "Planning Guide".

Additional hoisting points for different types of construction

Additional hoisting points are provided for those types of construction that differ from the basic types of construction Hoisting points (1), see Fig.).

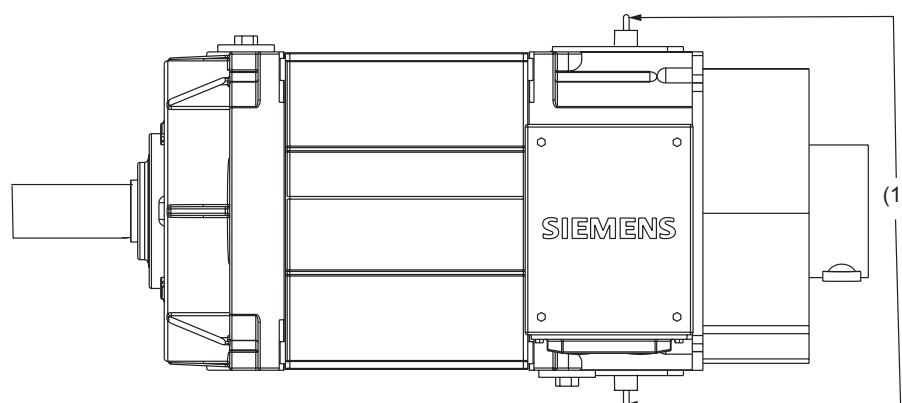

Figure 2-3 View from above onto type of construction IM B3
(1) Hoisting points

[ID: 388]

2.5.4 Regulations

Overview

The motors comply with the following regulations under IEC EN 60034:

Feature	Standard
Dimensions and operating characteristics	IEC EN 60034-1
Degree of protection	IEC EN 60034-5
Cooling	IEC EN 60034-6
Type of construction	IEC EN 60034-7
Noise emission	IEC EN 60034-9
Vibration severity levels	IEC EN 60034-14

[ID: 319]

2.5.5 Degree of protection

The three-phase motors of the 1PH7 series are built to degree of protection IP55 in accordance with IEC EN 60034-5.

The standard version of the motors is not suitable for operation in a salt-laden or corrosive atmosphere, nor for installation outdoors.

[ID: 390]

3 Installation / Assembly

3.1 Transport, storage

Instructions relevant for safety

Please observe the following instructions on the transportation and storage of motors.



Caution

Motors may only be attached to and hoisted by the main eyebolts that are located at the end shields. Auxiliary eyebolts, e.g. on fan cowls and cooler attachments, are suitable only for hoisting the respective parts.

To hoist the motor, in particular at attachments and built-on assemblies, use suitable cable-guidance or spreading equipment.

Observe the lifting capacity of the hoisting gear.

(See rating plate for weight.)

Table 3-1 Weights of standard versions (IM B3)

Type	Weight
1PH7 224	630 kg
1PH7 226	750 kg
1PH7 228	860 kg

Notice

If the motor is not immediately commissioned, then it should be stored in a dry room which is free from vibration and shock.

Transporting motors with a rotor shipping brace

Motors with cylindrical-roller bearings have a rotor shipping brace (shaft block), in order to prevent the bearings from becoming damaged during transportation/shipping.

- Only remove this brace before fitting the drive element.

Notice

Take other suitable measures to axially fix the rotor if the motor has to be transported after you have fitted the drive element.

[ID: 392]

3.2 Installation

Instructions relevant for safety



Caution

The enclosure components of electric motors can become very hot (possibly > 100 °C). Do not touch enclosure components while the motor is running or immediately after it has been running.

Caution

When positioning temperature-sensitive components (wires etc.), make sure that they are not in contact with the motor enclosure.

Notice

Also pay attention to the Technical Data on the rating plates on the motor enclosure.

Cooling conditions in general

- In the case of motors that are cooled by the ambient air, the cooling air must be able to flow unimpeded to and from the motors. Hot discharged air must not be reinducted (see also "Cooling").

Cooling conditions for motors with pipe connection

Motors that are configured to allow pipes to be connected and/or for operation with a separately driven fan must have pipes and a fan of suitable type and dimensioning mounted and connected to them.

Please refer to the table below for the potential pressure drop inside the motor for motors with a pipe connection:

Table 3-2 Pressure drop in motors with pipe connection

1PH7 22.	
Volumetric flow (V)	Pressure drop (Δp)
0.36 m ³ /s	900 Pa

Notice

Please consider the additional pressure drop that arises in the system when connecting the pipes.

Also ensure that:

- you comply with the conditions of the IP degree of protection.
Higher IP requirements may necessitate the installation of suitable filters and special positioning of the intake and outlet openings.
- units and wires are mounted without distortion.
- the shipping covers of the ventilation openings are removed.

Balancing quality

The rotors are dynamically balanced. In the case of shaft ends with feather keys, the method used to balance the rotors can be identified from the following coding to be found on the end face at the drive end of the shaft end:

- Code "H" means balancing with half a feather key (standard version); this means that in order to maintain the balancing quality it may be necessary to cut back the part of the feather key protruding from the drive element and the shaft profile if the motor has a short output element.
- "F" means balancing with a whole feather key (optional version).

Make sure that the balancing method of the power take-off element is correct!



Caution

Power take-off elements must only be fitted and pulled off with the aid of a suitable tool.
The feather keys are only locked against falling out during shipping.

Noise emission

Motors of the 1PH722 series have a measuring surface sound pressure level Lp(A) of approx. 76 dB(A) + 3 dB (tolerance) in a speed range from 0 through 4500 rpm.

Where the ventilation direction is from the N-end to the D-end, the motors have a measuring surface sound pressure level Lp(A) of 74 dB(A) + 3 dB (tolerance).

The motors are certified for a wide range of installation and operating conditions. In some cases these conditions (e.g. rigid or vibration-isolated foundation design, use of sound-absorbing elements) can have a very great influence on noise emissions.

When evaluating the noise levels at the workplaces of the system operators, consider the fact that the A-weighted sound pressure level (measured in accordance with DIN EN 21680 Tl.1) of 70 dB(A) is exceeded when the three-phase motors are operated at nominal load.

[ID: 394]

3.3 Mounting

Prerequisites

In order to ensure smooth, vibration-free motor operation, a stable foundation design is required, the motor must be precisely aligned, and the components that are to be mounted on the shaft end must be correctly balanced.

Removing the cover sheets

Cover sheets are attached by means of the screw positions on the motor feet.

The cover sheets (1) have to be removed before mounting the motor

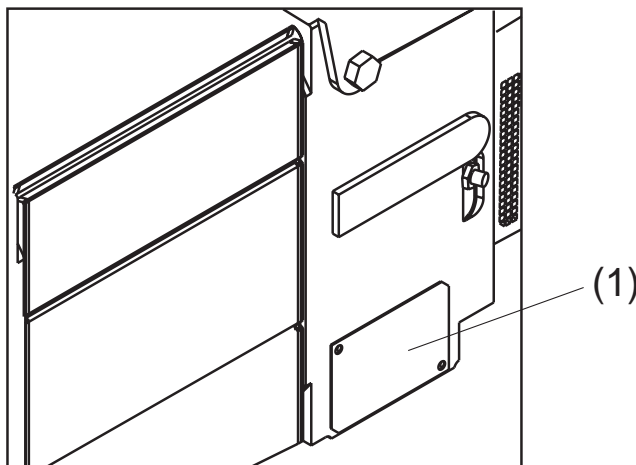

Figure 3-1 (1) Cover sheet (detailed view)

Caution

The cover sheets ensure the cooling of the motor.

Please make sure that the cover sheets are always screwed back onto the motor after mounting the motor via the motor feet.

Fixing by means of motor feet

If the motor needs to be aligned, position metal shims underneath the feet in order to prevent the motor from suffering distortion.

The number of shims should be kept as low as possible i.e. stack as few as possible.

Mounting bolts

To securely mount the motor and reliably transfer the drive torque, use motor mounting bolts (M12) with the required strength class (8.8) in accordance with ISO 898-1.

Notice

All flange motors must have stable suspension and be supported by means of the end-shield feet (foot-flange type of construction). When commissioning, make sure that the vibration values permitted in accordance with DIN ISO 10816 are observed.

Motors that are mounted with their feet on the wall due to their type of construction must be fixed in position by means of an adequately dimensioned form closure (e.g. by pinning or using a wall mounting strip).

[ID: 331]

3.4 Connecting the stator winding

Circuit diagram

Details with respect to wiring and connecting the motor winding are laid down in the circuit diagram enclosed. The circuit diagram is attached to the lid of the terminal box.

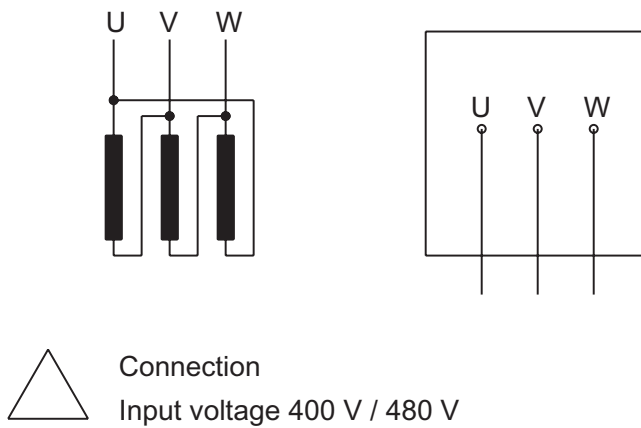

Figure 3-2 Circuit diagram

Select the connecting cables taking into account the rated current and the system specific conditions (e.g. ambient temperature, routing type etc. in accordance with IEC EN 60204-1).

Connecting using cable lugs

To connect the cables to the main terminals, select cable lugs that match the necessary cable cross-section and bolt size M12. The dependencies of the cable insertions with the different terminal boxes and the different machine types are shown in the following tables.

Table 3-3 Terminal box assignment, max. connectable cross-section per terminal

Motor type	Terminal-box type	Cable entry	Max. poss. outer diameter of cable[mm]	No. of main terminals	Max. connectable cross-section per terminal [mm ²]	Max. poss. current per terminal [A] (Reduction factor 0.6)
8. th digit of the MLFB = 2, 6						
1PH7224-..B	1XB7 322	2 x PG42	40	3 x M12	2 x 50	191
1PH7224-..D						
1PH7226-..B						
1PH7228-..B						
1PH7224-..U	1XB7 422	2 x M72 x 2	56	3 x M12	2 x 70	242
1PH7226-..D						
1PH7224-..L	1XB7 700	3 x M72 x 2	56	3 x 2 x M12	3 x 150	583
1PH7226-..F						
1PH7226-..L						
1PH7228-..D						

Motor type	Terminal-box type	Cable entry	Max. poss. outer diameter of cable[mm]	No. of main terminals	Max. connectable cross-section per terminal [mm ²]	Max. poss. current per terminal [A] (Reduction factor 0.6)
1PH7228-...F						
8. th digit of the MLFB = 7, 8						
1PH7224-...B	1XB7 322	2 x M50 x 1.5	38	3 x M12	2 x 50	191
1PH7224-...D						
1PH7226-...B						
1PH7228-...B						
1PH7224-...U	1XB7 422	2 x M63 x 1.5	53	3 x M12	2 x 70	242
1PH7226-...D						
1PH7224-...L	1XB7 700	3 x M75 x 1.5	68	3 x 2 x M12	3 x 150	583
1PH7226-...F						
1PH7226-...L						
1PH7228-...D						
1PH7228-...F						

Remove the insulation from the conductor ends so that the remaining insulation is almost long enough to reach the cable lug.

If necessary, insulate the cable lugs in order to maintain the minimum clearances in air of 10 mm and the 20 mm creepage distance normally present.

The tightening torque for M12 contact nuts and mounting bolts is 40 Nm.

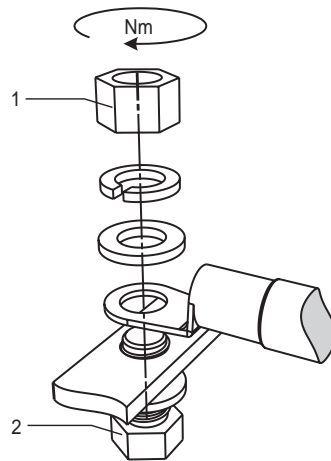

Figure 3-3 Tightening torques for contact nuts and mounting bolts
(1) contact nuts
(2) mounting bolts

Principles of fitting and laying cables

Lead in permanently laid entries using EMC cable glands. Screw the cable glands into the threaded holes in the unscrewable entry plate.

Arrange the exposed connecting cables in the terminal box such that the PE conductor has excess length and the insulation of the cable strands cannot be damaged.

Note

We recommend you use shielded cables whose shields are conductively connected to a large area of the metal terminal box of the motor (with an EMC cable gland made of metal).

Notice

Unused threads must be sealed with a metallic screw plug.

Internal equipotential bonding

The equipotential bonding between the earth terminal in the terminal box housing and the motor frame is established via the terminal box mounting bolts. The contact points underneath the bolt heads are bare metal and are protected against corrosion.

The standard terminal box cover mounting screws are adequate as potential bonding between the terminal box cover and terminal box itself.

Final checks

Before closing the terminal box, please check that:

- the electrical connections in the terminal box are tight and are in full compliance with the specifications above.
- the required clearances in air of 10 mm are maintained.
- no wire ends are standing proud.
- the inside of the terminal box is clean and free of any cable pieces.
- all seals and sealing surfaces are not damaged.
- the connecting cables are laid in an open arrangement and the cable insulation cannot be damaged.
- cable entries which are not used are sealed and the plugs are tightly screwed in (i.e. so that they can only be removed using the suitable tools).
- the right cable glands are fitted with respect to the correct degree of protection, method of laying, permissible cable diameter etc., as stated in the specifications.

Then close the terminal box.

Table 3-4 Tightening torque for the fixing screws on the lid

Bolt	Terminal box type	Tightening torque
M6	1XB7 322	4.5 Nm
M8	1XB7 422	11 Nm
M10	1XB7 700	22 Nm

[ID: 397]

3.5 Connecting the ground conductor

General

The cross-section of the ground conductor of the motor must comply with the regulations for electrical installations, e.g. DIN EN IEC 60204-1.

Connecting

Connect-up the ground-conductor in the motor terminal box. For this purpose, a clamping lug is provided at the appropriately marked connecting point for the ground conductor. This lug is suitable for connecting stranded conductors with cable lugs or ribbon cables with an appropriately shaped conductor end.

The ground conductor must also be connected to the end shield of the motor.

When making connections, ensure that

- the contact surface is clean and bright, and is protected with a suitable anti-corrosion agent, e. g. acid-free Vaseline.
- the flat and spring washers are located under the bolt head.

- the minimum necessary screw-in depth and the tightening torque for the clamping bolts must be maintained.

Mandatory tightening torques:

Bolt	Terminal box type	Tightening torque
M5	1XB7 322	2.6 Nm
M8	1XB7 422	11 Nm
	1XB7 700	11 Nm

[ID: 308]

3.6 Connecting the fan

Instructions relevant for safety

Please observe the following safety instructions relating to connecting a fan:

Caution

Provide a protective circuit that prevents the main motor from being switched on when the fan unit is not in operation.

Caution

Please note that the separately driven fan unit is only suitable for the direction of rotation shown by the direction-of-rotation arrow.

The fan must not be operated with the wrong direction of rotation as this could lead to the motor being destroyed.

Note

The direction-of-rotation arrow and the direction of movement of the fan impeller are indicated on the rear side of the blower.

If necessary, switch the direction of rotation by swapping over two phase conductors in the terminal box.

Fan connection for suction ventilation (D end to N end)

Connect up the fan in the terminal box of the fan unit.

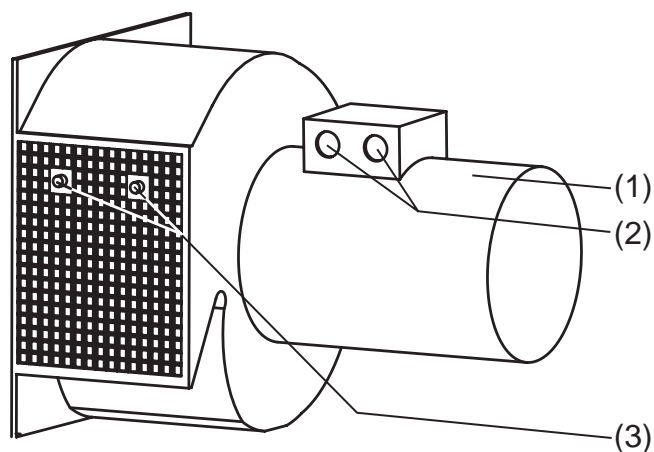

Figure 3-4 Detailed view of fan at 50 Hz
(1) fan unit terminal box
(2) cable entry
(3) screw positions for air outlet throttle sheet

Caution

If the motor is operated at 60 Hz, the air outlet throttle sheet included in the terminal box must be screwed on.

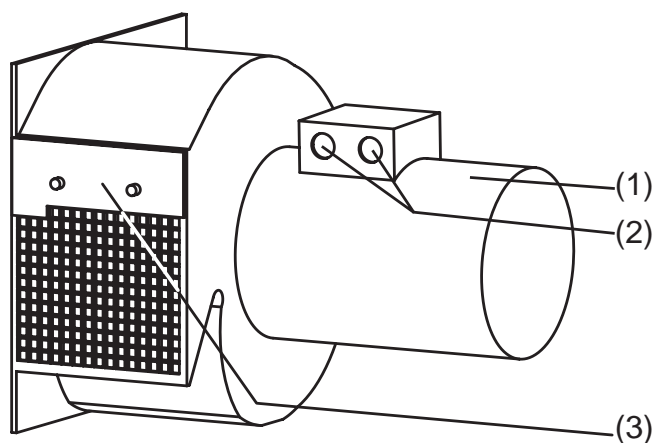

Figure 3-5 Detailed view of fan at 60 Hz
(1) fan unit terminal box
(2) cable entry
(3) air outlet throttle sheet

Fan connection for forced-draft ventilation (N end to D end)

Connect up the fan in the terminal box of the fan unit.

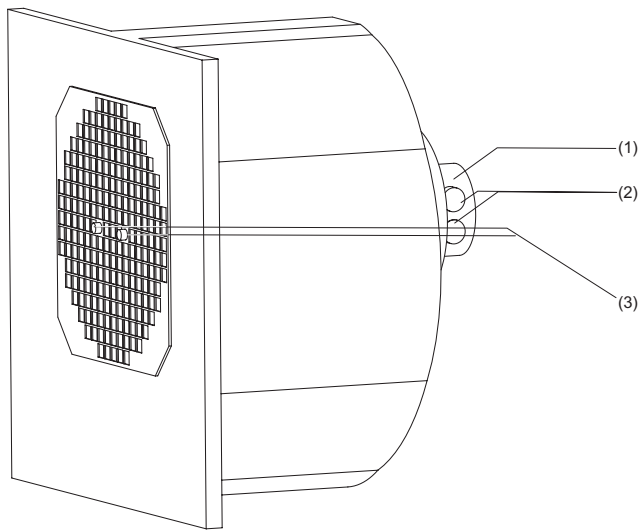

Figure 3-6 Detailed view of fan at 50 Hz
(1) fan unit terminal box
(2) cable entry
(3) screw positions for air inlet throttle sheet

Caution

If the motor is operated at 60 Hz, the air inlet throttle sheet included in the terminal box must be screwed on.

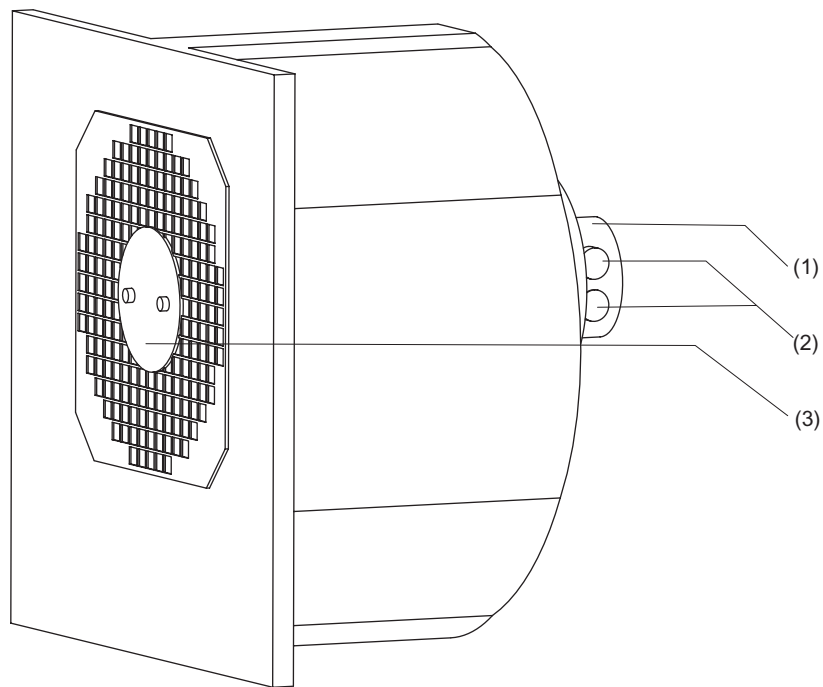

Figure 3-7 Detailed view of fan at 60 Hz
(1) fan unit terminal box
(2) cable entry
(3) air inlet throttle sheet

[ID: 398]

3.7 Connecting the speed sensor

Connecting

Connect the speed sensor to the terminal box by means of a plug-in connection (1). It is located on top of the box housing.

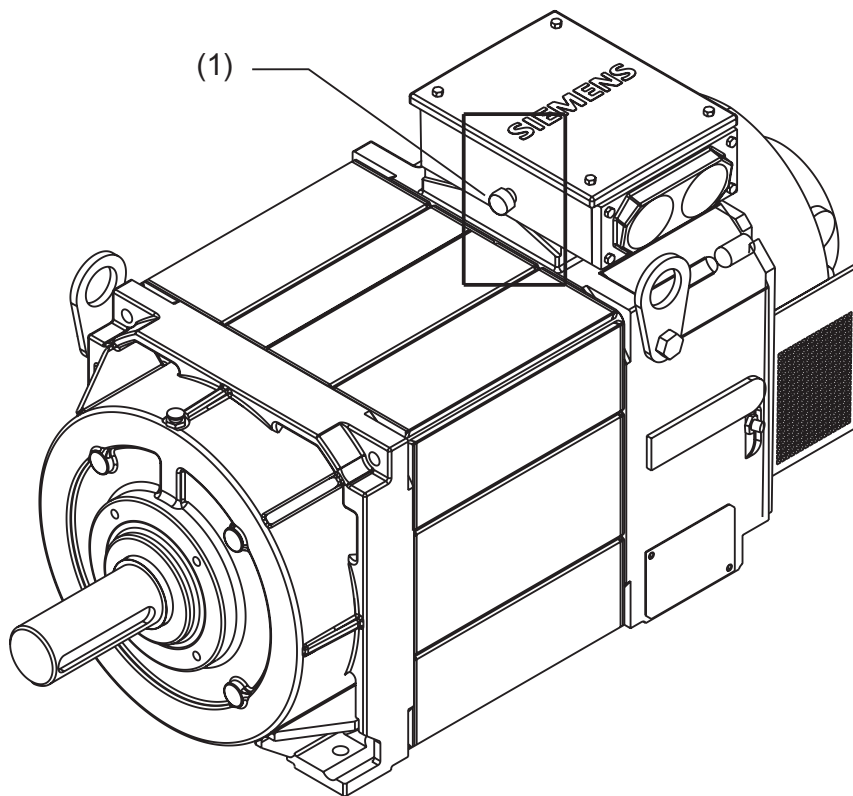

Figure 3-8 Detailed view: Plug-in connection

Note

The plug connection may differ from the standard layout in the case of special orders.
In the version "without sensor", an armored conduit union is located here.

[ID: 340]

3.8 Connecting the temperature sensor

Connecting

Connect the wires of the temperature sensor to the speed sensor connector with the aid of connecting leads (see section entitled "Connecting the speed sensor").

Note

The plug connection may differ from the standard layout in the case of special orders.
In the version "without sensor", an armored conduit union is located here.

[ID: 342]

4 Startup

4

4.1 Preparations

Safety instruction



Warning

Only expert persons should be entrusted with work on power installations.

Checking the insulation resistance

Note

There is no need to check the insulation resistance when commissioning. We only recommend doing so after long storage or shutdown periods.

After long storage or shutdown periods, the insulation resistance of the windings must be measured to ground with direct voltage.



Warning

During the measurement, and immediately afterwards, some of the terminals are at hazardous voltage levels and must not be touched.

Check the supply feeder cables connected in order to ensure that the line supply voltage cannot be connected.

Caution

Before you begin measuring the insulation resistance, please read the manual for the insulation resistance meter you are going to use.

The insulation resistance of the winding to the motor enclosure can only be measured accurately when the winding temperature is between 20 and 30°C:

When making the measurement, you must wait until the final insulation resistance value is reached (approx. 1 minute).

Limit values

The table below specifies the measuring circuit voltage and the limit values for the minimum insulation resistance and the critical insulation resistance:

	Rated voltage $U_N < 2 \text{ kV}$
Measuring circuit voltage	500 V (min. 100 V)
Minimum insulation resistance with new, cleaned or repaired windings	10 M Ω
Critical specific insulation resistance after a long operating time	2.5 M Ω /kV

Note the following points:

- Dry, new windings have insulation resistances of between 100 and 2000 M Ω , or possibly even higher values.

If the insulation resistance is close to the minimum value, then the cause could either be humidity and/or dirt accumulation.

Over its operating lifetime, the motor winding insulation resistance can drop due to ambient and operational influences. The critical insulation resistance at a winding temperature of 25°C is 2.5 M Ω

Notice

If the critical insulation resistance is less than or equal to this value, the windings must be dried or, if the fan is removed, cleaned thoroughly and dried.

Please note that the insulation resistance of dried, clean windings is lower than that of warm windings. The insulation resistance can only be evaluated accurately when measured on a winding that has been cooled down to room temperature (approx. 20 to 30°C).

Notice

If the measured value is close to the critical value, the insulation resistance should be subsequently checked at appropriately frequent intervals.

[ID: 344]

4.2 Measures to be performed prior to commissioning

Overview



Warning

This list does not claim to be exhaustive.

It may be necessary to make additional checks and tests corresponding to the actual plant/system situation.

After assembling the motor in line with technical requirements and before commissioning the system, check that:

- the motor has been assembled and aligned properly.
- the cover sheets have been remounted correctly, to ensure the cooling of the motor.
- the operating conditions are in accordance with the data specified on the nameplate.
- any supplementary motor monitoring devices and equipment have been correctly connected and are functioning.
- appropriately configured control functions and speed monitoring equipment ensure that speeds cannot exceed the permissible speeds stated on the rating plate.
- the drive elements have the correct setting conditions
(e.g. alignment and balancing of couplings, belt tension on belt drives, tooth flank and tip clearance on gear drives, radial clearance).
- the minimum insulation resistance values are observed.
- the grounding and equipotential bonding connections have been correctly made.
- all mounting screws, connecting elements and electrical connections are tight.
- the rotor can be spun without coming into contact with the stator.
- all shock protection measures for moving and live parts have been taken.
- if the second shaft end has not been used, its feather key has been secured to prevent it being thrown out.
- all separately driven fans fitted are ready for operation and have been connected such that they rotate in the direction specified.
- the flow of cooling air is not impeded.
- all brakes are operating correctly.

Notice

Grease loses its lubricating property over time.

The bearings must be relubricated or replaced after extended periods (>2 years) of storage or if the motor has not been operated during this time.

[ID: 399]

4.3 Energizing

Measures

Before you energize the motor, make sure that the parameters of the frequency converter have been assigned correctly.

We recommend you use appropriate commissioning tools (e.g. Drive ES).

Caution

If the motor is running irregularly or emitting abnormal noises, de-energize it and determine the cause of the fault as the motor runs down.

Notice

The critical speed $n_{\max} = 4500$ rpm is the maximum operating speed permissible over short periods.

[ID: 400]

5 Operation

5

5.1 Operation

Safety information



Warning

Please follow all instructions contained in the "Safety information" section of these Operating Instructions precisely and ensure that only persons who have the necessary specialist know-how are entrusted to carry out work on power installations.

Covers which are designed to prevent active or rotating parts from being touched, or which are necessary to ensure correct air guidance and thus more effective cooling, must not be opened during operation.

An appropriately configured control system and speed monitoring equipment must be used to ensure that speeds cannot exceed the permissible speeds stated on the rating plate.

Energizing

Always refer to the respective manual of the frequency converter when energizing.

After starting the motor, observe it for a while to see if it is running smoothly and check the monitoring devices.

Operation

Monitor operation and the monitoring devices regularly and record the values you read off.



Warning

All deviations from normal operation, such as higher power consumption, higher temperatures and vibration levels, unusual noises and odors and tripped monitoring devices, are indications that the motor is no longer functioning correctly.

In this case, the maintenance technician must be immediately notified in order to prevent disturbances that could either directly or indirectly lead to severe personal injury or substantial material damage.

If in doubt, switch off the drive in question immediately.

[ID: 348]

5.2 Stoppages

Measures when motors are at standstill and ready for operation

- For longer periods, where the motor is not being used, either energize the motor at regular intervals (roughly once a month) or at least spin the rotor.
- Please refer to the section "Energizing", before restarting the motor.

Notice

If the motor is out of service for extended periods of time, implement suitable anti-corrosion, preservation, and drying measures.

Note

When restarting the motor after a long shutdown period, carry out the measures recommended in the section entitled "Commissioning".

[ID: 349]

5.3 De-energizing

Measures

Always refer to the respective manual of the frequency converter when de-energizing.

Note

The fan must be shut down during longer periods in which the motor is not operated.

Notice

We strongly recommend that you continue operating the fan for approx. 30 min after shutting down the motor.

[ID: 351]

6 Faults

6.1 Fault diagnosis table

Diagnosis table for mechanical and electrical faults

The tables below list general faults caused by mechanical and electrical influences.

Table 6-1 Diagnosis table for mechanical faults

Overview of mechanical faults					
Mechanical fault characteristics					
- rubbing/grinding noise		↴			
- high temperature rise			↴		
- radial vibration				↴	
- axial vibration					↴
Possible causes of fault	Remedial measures ¹⁾				
- Rotating parts rubbing/grinding	Determine cause and adjust parts	x			
- air supply restricted, possibly wrong direction of rotation of fan	Check air passages, clean filter, replace fan if necessary		x		
- Rotor not balanced	Rebalance rotor			x	
- Rotor out of true, shaft bent	Consult the manufacturer			x	
- Poor alignment	Align motor unit, check coupling ²⁾			x	x
- Coupled motor not balanced	Rebalance coupled motor			x	
- Shocks from coupled motor	Check coupled motor				x
- Imbalance originating from gearing	Adjust/repair gearing			x	x
- Resonance with the foundation	After consultation, reinforce foundation			x	x
- Changes in foundation	Determine cause of changes, eliminate if necessary; realign motor			x	x
¹⁾ As well as eliminating the cause of the fault (as described under "Remedial measures"), you must also rectify any damage the motor may have suffered. ²⁾ Take into account possible changes due to a rise in temperature.					

Table 6-2 Diagnosis table for electrical faults

Overview of electrical faults	
Electrical fault characteristics	
- Motor will not start up	Note: If electrical faults occur, please refer to the manual for the frequency converter.
- Motor starts up slowly	
- Drumming noise during startup	
- Drumming noise during operation	
- Drumming noise in time with twice slip frequency	
- High temperature rise at no load	
- High temperature rise under load	
- High temperature rise of individual winding sections	

[ID: 353]

7 Maintenance

7

7.1 Maintenance

7.1.1 Maintenance instructions

Safety information



Warning

Please follow all the instructions contained in the "Safety information" section of these Operating Instructions precisely and ensure that only persons who have the necessary specialist know-how are entrusted to carry out work on power installations.

In addition to the main phases, also ensure that supplementary and auxiliary circuits are also de-energized.



Caution

Be careful of those parts of the motor that get hot and let them cool down before starting maintenance work.

Safety rules

Always comply with the following safety rules before starting maintenance work:



Danger

- Isolate
 - Safeguard against reclosure
 - Disconnect from supply
 - Fence off or cover up adjacent live parts
-

Other safety-related measures



Caution

When cleaning using compressed air, make sure you use suitable extraction equipment and wear protective gear (safety goggles, protective suit, etc.).

Caution

If you use chemical cleaning agents, observe the instructions and any warnings given in the relevant safety data sheet.

Chemical agents must be compatible with the components/parts, especially when it contains plastics.

Note

If anything is unclear, we **urgently** recommend that you consult us stating the type and serial number of the three-phase motor or get one of the SIEMENS Service Centers (see section entitled "SIEMENS Service Centers") to carry out maintenance work for you.

[ID: 401]

7.1.2 Maintenance intervals

General

Careful and regular maintenance, inspections and overhauls are essential for detecting and eliminating faults in good time before they can cause any damage.

Operating situations and characteristics can vary widely. For this reason, only general maintenance intervals can be specified here. Maintenance intervals should therefore be scheduled to suit the local conditions (dirt, starting frequency, load, etc.).

Notice

In the event of faults or extraordinary conditions that lead to the three-phase motor being overloaded either electrically or mechanically (e.g. overload, short circuit, etc.), carry out the inspections immediately.

Measures, intervals

Measures after service period intervals have elapsed:

Table 7-1 Service period intervals

Measures	Service period intervals	Intervals
Initial inspection	after 500 operating hours	after 6 months at the latest
Continuous lubrication (Machines without regreasing device)	Belt operation 12 000 h	
	Coupling operation 20 000 h	
Machines with regreasing device (option)	(see lubrication instruction plate)	
Cleaning	depending on local degree of pollution	
Main service	approx. every 16,000 operating hours	

[ID: 356]

7.1.3 Bearings

Description

The three-phase motors have grease-lubricated, rolling-contact bearings. A regreasing device is optional.

A deep-groove ball bearing is installed at the non drive end as a locating bearing. Depending on the type of load, a deep-groove ball bearing or cylindrical-roller bearing is installed at the drive end as a floating bearing.

The respective bearing assignment, the correspondingly permissible lateral forces and the minimum loads when cylindrical-roller bearings are installed at the drive end can be found in the catalog or you can ask us for this data.

The D-end bearing contains built-in spring elements which help to rebalance the axial play of the external bearing rings.

Notice

Permanently lubricated bearings should be exchanged approx. every three years, regardless of the length of use (operating hours)

[ID: 359]

7.1.4 Lubrication (optional)

Relubrication intervals

The relubrication intervals are stated on the lubrication instruction plate of the three-phase motor.

Notice

Observe the basic lubrication interval (see section entitled "Measures, intervals").

Notice

If there is a long interval between delivery and commissioning of the motor, the bearings must be relubricated.

The grease change intervals apply for normal loads, operation at speeds corresponding to those specified on the nameplate, precision-balanced running, almost neutral ambient air and the use of high-quality rolling-contact bearing greases.

Grease types

The following high-quality rolling-contact bearing greases have been tested and are suitable:

Table 7-2 Rolling-contact bearing greases

K3N-greases
ESSO / Unirex N
ARAL / Aralub 4340
DEA / Glissando 30
ESSO / Beacon 3
FUCHS / Renolit FWA 220
SHELL / Alvania RL3
SHELL / Alvania R 3
WINTERSHALL / Wiolub LFK 3

These greases have Lithium soap as thickening agent and mineral oil as the base oil. They exceed the standard requirements of DIN 51825 in several important respects, and are therefore compatible with the specified regreasing intervals.

Notice

Never mix greases that have different thickening agents and base oils.

Initial lubrication

ESSO Unirex N grease is used for initial lubrication of the bearings (prior to delivery).

Lubricating using the regreasing device

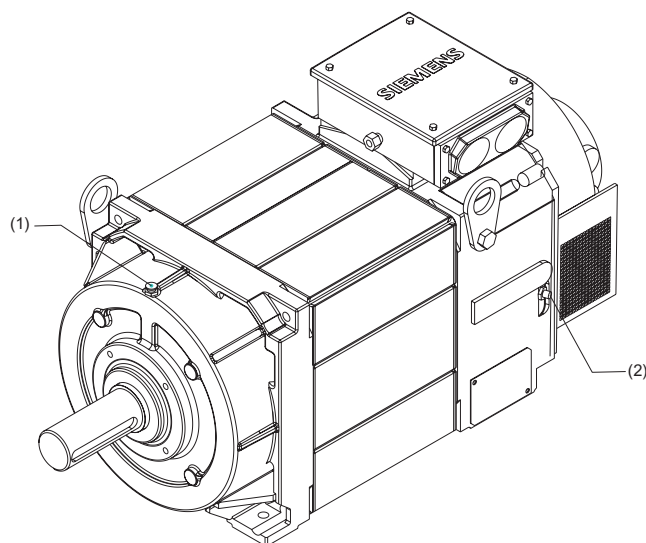

Figure 7-1 Drive end and non-drive end shields with grease nipples
(1) drive end (D end) grease nipple
(2) non-drive end (N end) grease nipple

1. Clean the grease nipples at the drive end and non drive end.
2. Press in the grease and quantity of grease specified (see lubrication instruction plate).

Note

The shaft should rotate so that the new grease can be distributed throughout the bearing.

The bearing temperature rises sharply at first, then drops to the normal value again when the excess grease is displaced out of the bearing.

[ID: 361]

7.1.5 Cleaning

Cleaning the greasing channels and used grease chambers

The used grease collects outside each bearing in the used grease chamber of the outer bearing cap. Remove the used grease when you replace a bearing.

Notice

You have to separate the active parts of the bearings to replace the grease that is in the greasing channel.

Cleaning the cooling air passages

Regularly clean the cooling air passages through which the ambient air flows, e.g. using dry compressed air.

Notice

The frequency of the cleaning intervals depends on the local degree of pollution.



Warning

Particularly when cleaning using compressed air, make sure you use suitable extraction equipment and wear protective gear (safety goggles, breathe filter, etc.).

[ID: 363]

7.2 Inspection

7.2.1 General inspection specifications

Instructions relevant for safety

Notice

The required regreasing intervals for rolling-contact bearings (optional) are not the same as the servicing intervals. It is essential to adhere to them.

Note

When servicing a three-phase motor, it is generally not necessary to dismantle it. The motor only has to be dismantled if the bearings are to be replaced.

[ID: 366]

7.2.2 Initial inspection

Inspection interval for initial inspection

The initial inspection after assembly or commissioning of the three-phase motor is, under normal circumstances, conducted after approx. 500 operating hours, but at the latest after 6 months.

Conducting the initial inspection

- Check while the motor is running that:
 - the equipment conforms to the stated electrical characteristics.
 - the smooth running characteristics and motor noise during operation have not deteriorated.
- Check while the motor is shut down that:
 - the motor foundation has no indentations or cracks.

Notice

This list does not claim to be exhaustive.

Further tests are also necessary in line with the additional instruction manuals assigned (e.g. bearings, cooler, etc.) or in line with the particular system-specific conditions.

Notice

Inadmissible deviations detected during this inspection must be eliminated immediately.

[ID: 367]

7.2.3 Main service

Inspection interval for major inspection

The major inspection is conducted after approx. 16,000 operating hours or at the latest after 2 operating years.

Conducting the major inspection

- Check while the motor is running that:
 - the equipment conforms to the stated electrical characteristics.

- the smooth running characteristics and motor noise during operation have not deteriorated.
- Check while the motor is shut down that:
 - the motor foundation has no indentations or cracks.
 - the motor is aligned within the permissible tolerance ranges.
 - all of the mounting bolts for the mechanical and electrical connections are tight.
 - the winding insulation resistances are sufficiently high.
 - cables and insulating parts and components are in a good condition and are not discolored.

Notice

Inadmissible deviations detected during this inspection must be eliminated immediately.

[ID: 368]

7.3 Repair

7.3.1 Instructions for repair

Qualified persons

Only properly qualified persons should be entrusted with the commissioning and operation of machines and equipment. Qualified persons, as far as the safety instructions given in this manual are concerned, are those who have the necessary authorization to commission, ground and identify equipment, systems and circuits in accordance with the relevant safety standards.

Instructions relevant for safety



Warning

Before you begin working on the three-phase motor, in particular before you open the covers of active parts, make sure that the three-phase motor or system is properly isolated.

Notice

Whenever you have to transport the three-phase motor, pay attention to the instructions given in the section entitled "Transport, storage".

[ID: 370]

7.3.2 Dismantling

Disassembly instructions

The drawings and parts lists do not contain any detailed information about the type and dimensions of retaining elements and the like.

Notice

Before you start dismantling them, you should therefore mark up the respective assignment of retaining elements and the layout of the internal connections for assembly if they have to be disconnected for maintenance work.

Notice

Use pullers or suitable devices to disassemble parts and components attached to the motor shaft.

Three-phase motors of a vertical type of construction can be dismantled in the horizontal position.

Working with three-phase motor in vertical position

Notice

When working on the locating bearing when the three-phase motor is in its vertical position, support the rotor.

When attaching the rotor in the vertical position, make sure that the centering recesses in the shaft ends (DIN 332) - DS M20) have a recessed thread; eye-bolts must have a minimum length of 35 mm.

The rotor weights for the 1PH7 three-phase motors can be found in the following table:

1PH722.			
Size	224	226	228
Weight (kg)	170	215	255

Disassembling the three-phase motor

- To disassemble the motor, disconnect the connecting cables from the terminals and the entry plate from the terminal box housing.

In this way, the respective positioning of the cables to one another and sealing of the cables in the cable entries is largely maintained.

- Disconnect the connecting cables in the terminal box of the fan motor and, if necessary, the cable from the ground terminal. Furthermore, disconnect the speed sensor plug connector.

Wiring

The terminal diagram (see "Connecting the stator winding") contains the conditions required for line connection.

Installing the active parts of the bearings

Notice

We recommend that you label the components that comprise the active part of the bearing before dismantling them, in order to ensure correct reassembly.

Notice

When dismantling and assembling the bearings, make sure that you match up the components correctly (bearings, preloading springs, equalizing rings, caps with different centering length, etc.), especially when the bearings at the drive end and non-drive end are the same size.

Notice

Label the components before dismantling.

Notice

Whenever you work on the locating bearing when the three-phase motor is in its vertical position, support/unload the rotor.

Disassembling the speed sensor

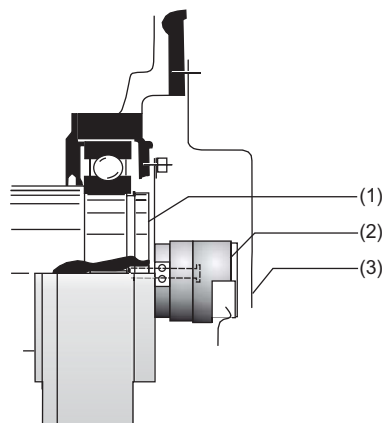

Figure 7-2 Detailed view of the speed sensor

- (1) Shaft
- (2) Speed sensor
- (3) Sensor cover

Notice

Always disassemble the speed sensor before you dismantle the three-phase motor, in order to prevent it from becoming damaged.

To disassemble the speed sensor, proceed as follows:

- Screw off the sensor cover.
- Unscrew the screw connections of the sensor from the end shield and the sensor lead connection.
- Pull the sensor off the shaft with the aid of a puller.

[ID: 402]

7.3.3 Re-assembly

Re-assembly instructions

If possible, assemble the motor on a straightening plate. This ensures that the feet surfaces are all on the same level.

Notice

When mounting the end shield, make sure that the windings that project from the stator housing do not become damaged.

Notice

Take great care and pay attention to cleanliness when fitting and assembling the bearings.

Sealing measures when reassembling

Due to the stricter requirements of degree of protection IP55, joint sealant must be used for motors from the 1PH7 series.

Clean bare joints between parts before reassembling (e.g. between enclosures, end shields and the active parts of bearings).

Coat the bare joints between parts with a non-hardening sealant, e.g. MARSTON HYLOMAR SQM32M.

Note

MARSTON HYLOMAR SQM32M sealant can be ordered from W. Kopp, Schlesierstrasse 9, 97268 Kirchheim, Germany, or directly from Marston Bentley Domsel GmbH, Bergheimer Str. 15, 53909 Zülpich, Germany.

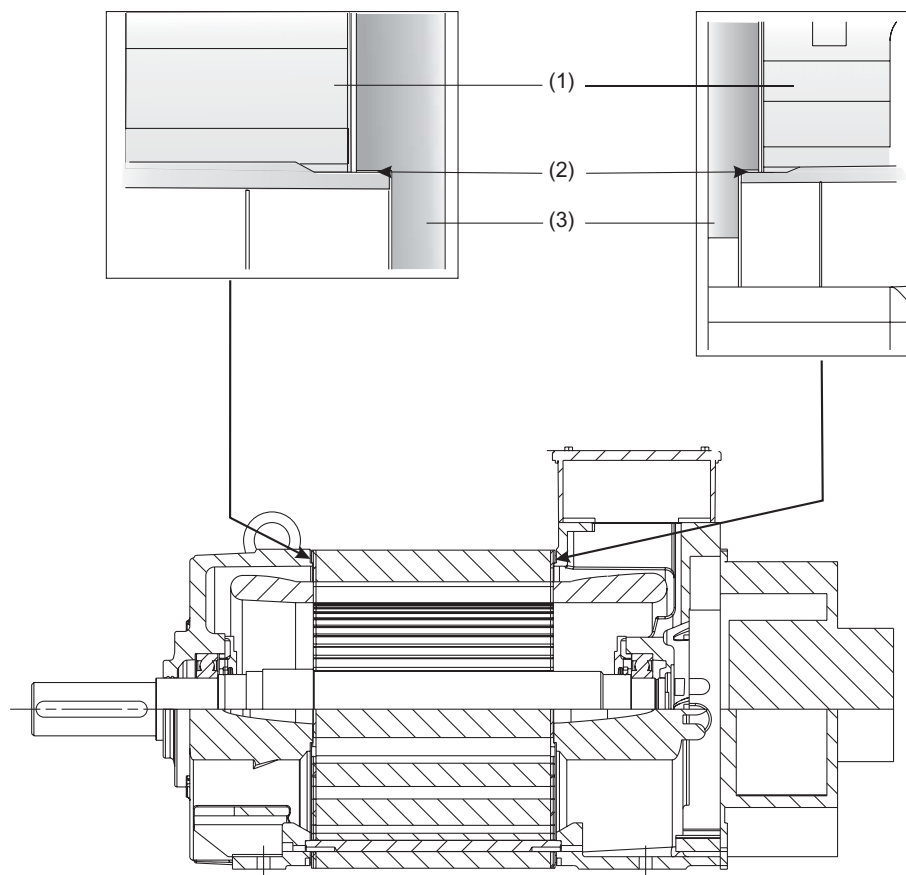

Figure 7-3 Sealing gap between enclosure and end shields

- (1) End shields
- (2) Sealing gaps
- (3) Housing

Before you screw on the end shields, seal the gaps (2) with MARSTON HYLOMAR SQ32M sealant.

Notice

Check the sealing elements fitted (e.g. at the terminal boxes) and replace them if they do not provide an adequate seal.

Notice

Follow the application and safety instructions of the manufacturer when using the sealant.

Installing the active parts of the bearings

Notice

Before mounting the bearings, ensure that the parts and components that are to be located on the shaft inside the bearing have been mounted beforehand!

To fit the bearings on the shaft, heat them up to about 80°C in oil or air.

Then push the bearings onto the shaft up to its shoulder.

Notice

Avoid any heavy blows that might damage the bearings.

Fill the bearings with specified grease (see section entitled "Types of grease") until it is flush.

Also observe the following installation condition:

- If rotary shaft seals without helical spring are installed, the replacement part must also be installed without a spring.

[ID: 377]

7.3.4 Bolted connections

Tightening torques for bolted connections

The bolted connections with metal contact surfaces (end shields, bearing cartridge parts, terminal box parts bolted onto the stator frame) should be tightened to the following torques, depending on the thread size.

Tightening torques (Nm, with a ± 10% tolerance) for a thread size of

M6	M8	M10	M12	M16	M20	M24	
8	20	40	70	170	340	600	Nm

Please refer to the relevant sections and drawings for all other tightening torques (electrical connections and bolted connections for parts with flat gaskets).

Bolt locking devices

Nuts or bolts that are mounted together with locking, resilient and/or force-distributing elements (e.g. tab washers, spring lock washers, etc.) must be refitted together with identical, fully functional elements.

Always renew positive-action locking elements!

[ID: 379]

8 Spare parts

8.1 Orders for spare parts

General

In addition to the exact part designation, please specify the machine type and the serial number in all orders for spare parts.

The type and serial number can be found on the nameplate. The serial number is also stamped on the end face of the shaft end on the drive end.

The part designation should be identical to the designation stated in the list of spare parts and specified together with the appropriate part number.

Example: End shield, D-end (Part 5.00)

See "Nameplate" section for the motor type and serial number.

Commercially available, standard components can be used, but ensure that they have the same type of construction, dimensions, strength class etc..

When replacing rolling-contact bearings, in addition to the bearing identification code, the replacement code for the bearing version is required. Both codes are specified on the lubrication instruction plate and in the motor documentation, or can also be taken from the installed bearings.

[ID: 382]

8.2 Spare parts 1PH7

Spare parts

Spare part no.	Description
3.10	Gamma ring
3.40	Deep-groove ball bearings (floating bearing)
3.41	Cylindrical-roller bearing
3.47	Self-aligning washer
3.60	Inner bearing cap

4.30	Retaining ring
4.40	Deep-groove ball bearings (floating bearing)
4.50	Inner bearing cap
5.00	End shield (Drive end)
6.00	End shield (Non drive end)
6.44	Top cover
6.80	Sensor cover
8.00	Rotor, complete
10.00	Stator housing (with laminated core and winding)
10.53	Hoisting lug
13.80	Lubricating nipple
Terminal box type	
20.20	Terminal box with terminal support
20.30	Lid (terminal box)
20.50	Entry plate (terminal box)
32.12	Fan unit complete
55.12	Speed sensor

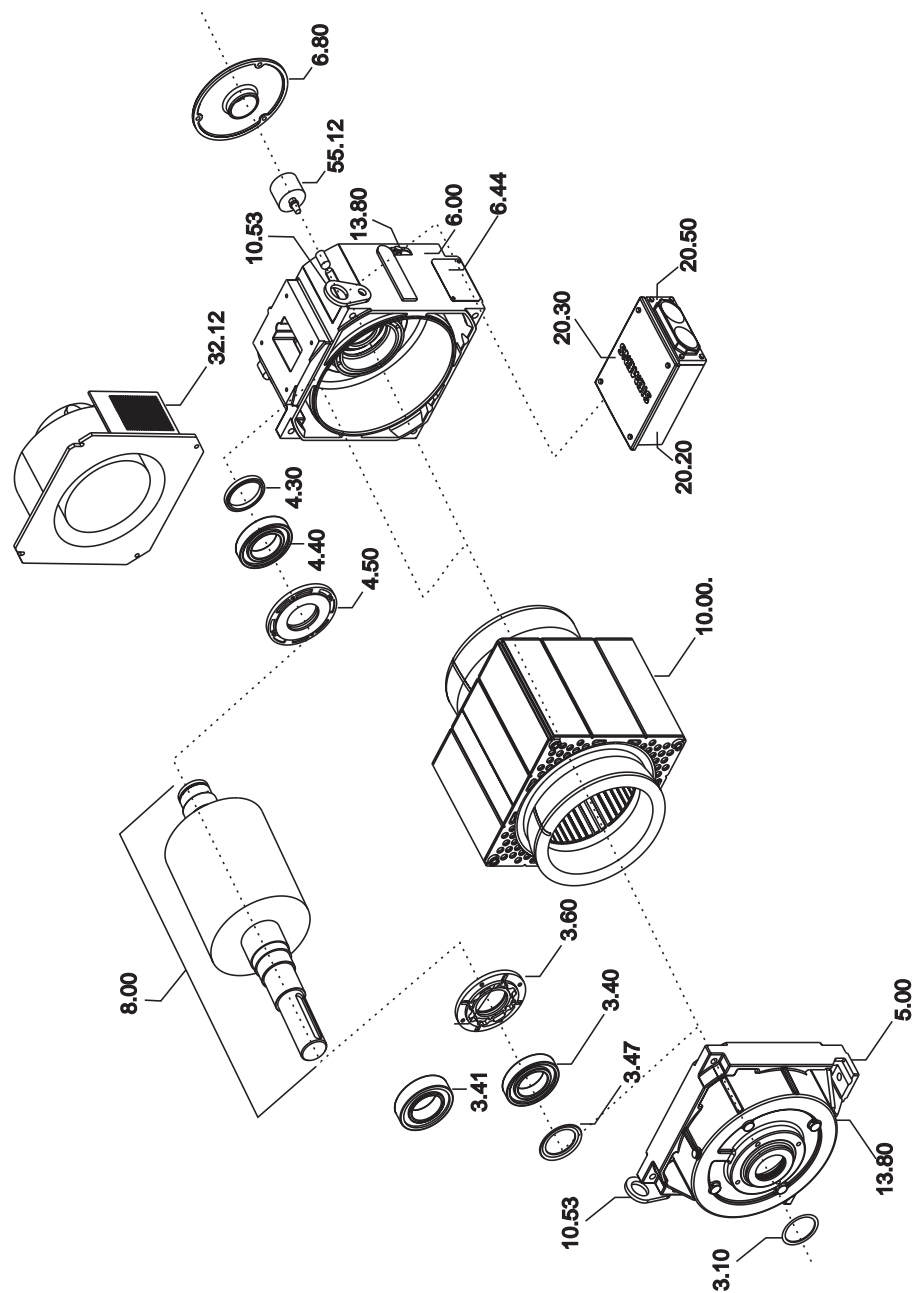

Figure 8-1 Spare parts 1PH7
[ID: 386]

9 Supplementary instructions (options, third-party suppliers)

9

AA U161 Konformitätserklärung
AA U151 Herstellererklärung

SIEMENS AG

Group: Automation and Drives (A&D)

Division Large Drives (LD)

Postfach 4848, D-90327 Nürnberg

www.siemens.com