



SV670P Series Servo Drive Installation Guide



Industrial
Automation



Intelligent
Elevator



New Energy
Vehicle



Industrial
Robot



Rail
Transit



Data code 19011868 A01

Preface

Introduction

Thank you for purchasing the SV670P series servo drive developed by Inovance.

The SV670P series servo drive is a high-end servo drive designed based on global-leading standards and high-end application needs. It is featured with high speed, high precision, high performance, and tuning-free Function.

The servo drive covers a power range from 0.05 kW to 7.5 kW and carries Modbus communication interfaces to work with the host controller for a networked operation of multiple servo drives. The drive comes with the ITune function which supports adaptive stiffness level setting, inertia auto-tuning, and vibration suppression for easy use. The servo drive, together with an MS1 series high-response servo motor (with ultra-low, low or medium inertia) equipped with a 23-bit single-turn/multi-turn absolute encoder, serve to deliver a quiet and stable operation and accurate process control through the fully closed-loop function and internal process segment function.

The drive also offers dynamic braking. The drive aims to achieve quick and accurate position control, speed control, and torque control through high-performance solutions for automation equipment in such industries as electronic manufacturing, lithium batteries, manipulators, packaging, and machine tools.

This guide presents installation of the servo drive, including installation steps, mechanical installation, and electrical installation.

More Documents

Name	Data Code	Description
SV670P Series Servo Drive Selection Guide	19011852	Provides instructions on product selection, including the list of supporting components, technical data on the drive and motor, and the selection guide of cables.
SV670P Series Servo Drive installation Guide	19011868	Presents installation of the servo drive, including installation steps, , mechanical installation, and electrical installation.
SV670P Series Servo Drive Hardware Guide	19011854	Presents electrical design guidance of the equipment, description of terminals, required certificates and standards and solutions to common EMC problems.
SV670P Series Servo Drive Commissioning Guide	19011856	Presents servo commissioning, parameter descriptions, including the operating panel, commissioning software, commissioning procedure and a parameter list.

Name	Data Code	Description
SV670P Series Servo Drive Function Guide	19011866	Presents functions and parameters, including function overview, basic servo functions, adjustment and parameter list.
SV670P Series Servo Drive Communication Guide	19011871	Presents functions and parameters of the servo drive, including Modbus communication configuration, parameter descriptions, and communication application cases.
SV670P Series Servo Drive Troubleshooting Guide	19011869	Introduces faults and fault levels, the troubleshooting process, warning codes and fault codes.
SV670P Series Servo Drive Maintenance Guide	19011870	Provides instructions on maintenance and repair of the equipment.
SV670P Series Servo Drive Safety Guide	19011867	Presents the safety function and related certifications and standards, wiring, commissioning process, troubleshooting, and functions.
SV670P Series Servo Drive Manual Package	PS00005526	Provides information on selection, installation, commissioning, function, troubleshooting and parameters of the equipment.

Revision History

Date of Revision	Version	Description
2022-06	A01	<ul style="list-style-type: none"> Updated the schematic diagram of the drive. Added information on the dust-proof plug for mechanical installation.
2022-04	A00	First release.

Document Acquisition

This manual is not delivered with the product. You can obtain the PDF version by visiting:

- <http://www.inovance.com>.
- Scan the QR code on the equipment to acquire more.

Table of Contents

Preface	1
General Safety Instructions	4
1 Precautions	11
2 Installation Flow Chart	12
3 Preparation	13
3.1 Installation Environment	13
3.2 Installation Clearance	14
3.3 Installation Dimensions	16
3.4 Optional Parts	18
3.5 Cable Preparation	19
4 Unpacking Inspection	21
5 机械安装	23
5.1 Safety Cautions	23
5.2 Pre-Inspection	24
5.3 Installing the Absolute Encoder Battery	25
5.4 Mounting the Drive	26
5.5 Installing the Motor	27
5.6 Post-Inspection	31
6 电气安装	32
6.1 Safety Cautions	32
6.2 Wiring of the Power Supply	32
6.3 Wiring with the Motor	36
6.4 Post-Inspection	38

General Safety Instructions

Safety Precautions

- This section explains the safety precautions that need to be observed to use this product correctly. Before using this product, please read the instruction manual and correctly understand the relevant information of safety precautions. Failure to comply with the safety precautions may result in death, serious injury, or equipment damage.
- "CAUTION", "WARNING", and "DANGER" items in the guide only indicate some of the precautions that need to be followed; they just supplement the safety precautions.
- Use this equipment according to the designated environment requirements. Damage caused by improper use is not covered by warranty.
- Inovance shall take no responsibility for any personal injuries or property damage caused by improper use.

Safety Levels and Definitions



Indicates that failure to comply with the notice will result in death or severe personal injuries.



Indicates that failure to comply with the notice may result in death or severe personal injuries.



Indicates that failure to comply with the notice may result in minor or moderate personal injuries or equipment damage.

General Safety Instructions

- Drawings in the selection guide are sometimes shown without covers or protective guards. Remember to install the covers or protective guards as specified first, and then perform operations in accordance with the instructions. Install the covers or protective guards as specified, and use the equipment in accordance with the instructions described in the user guide.
- The drawings in the guide are shown for illustration only and may be different from the product you purchased.

Unpacking **WARNING**

- Do not install the equipment if you find damage, rust, or signs of use on the equipment or accessories upon unpacking.
- Do not install the equipment if you find water seepage or missing or damaged components upon unpacking.
- Do not install the equipment if you find the packing list does not conform to the equipment you received.

 **CAUTION**

- Check whether the packing is intact and whether there is damage, water seepage, dampness, and deformation before unpacking.
- Unpack the package by following the unpacking sequence. Do not strike the package violently.
- Check whether there is damage, rust, or injuries on the surface of the equipment and equipment accessories before unpacking.
- Check whether the package contents are consistent with the packing list before unpacking.

Storage and Transportation **WARNING**

- Large-scale or heavy equipment must be transported by qualified professionals using specialized hoisting equipment. Failure to comply may result in personal injuries or equipment damage.
- Before hoisting the equipment, ensure the equipment components such as the front cover and terminal blocks are secured firmly with screws. Loosely-connected components may fall off and result in personal injuries or equipment damage.
- Never stand or stay below the equipment when the equipment is being hoisted by the hoisting equipment.
- When hoisting the equipment with a steel rope, ensure the equipment is hoisted at a constant speed without suffering from vibration or shock. Do not turn the equipment over or let the equipment stay hanging in the air. Failure to comply may result in personal injuries or equipment damage.

 CAUTION

- Handle the equipment with care during transportation and mind your steps to prevent personal injuries or equipment damage.
- When carrying the equipment with bare hands, hold the equipment casing firmly with care to prevent parts from falling. Failure to comply may result in personal injuries.
- Store and transport the equipment based on the storage and transportation requirements. Failure to comply will result in equipment damage.
- Avoid storing or transporting the equipment in environments with water splash, rain, direct sunlight, strong electric field, strong magnetic field, and strong vibration.
- Avoid storing the equipment for more than three months. Long-term storage requires stricter protection and necessary inspections.
- Pack the equipment strictly before transportation. Use a sealed box for long-distance transportation.
- Never transport the equipment with other equipment or materials that may harm or have negative impacts on this equipment.

Installation

 DANGER

- The equipment can be operated by well-trained and qualified professionals only. Non-professionals are not allowed.

 WARNING

- Read through the guide and safety instructions before installation.
- Do not install this equipment in places with strong electric or magnetic fields.
- Before installation, check that the mechanical strength of the installation site can bear the weight of the equipment. Failure to comply will result in mechanical hazards.
- Do not wear loose clothes or accessories during installation. Failure to comply may result in an electric shock.
- When installing the equipment in a closed environment (such as a cabinet or casing), use a cooling device (such as a fan or air conditioner) to cool the environment down to the required temperature. Failure to comply may result in equipment over-temperature or a fire.
- Do not retrofit the equipment.
- Do not fiddle with the bolts used to fix equipment components or the bolts marked in red.
- When the equipment is installed in a cabinet or final assembly, a fireproof enclosure providing both electrical and mechanical protections must be provided. The IP rating must meet IEC standards and local laws and regulations.
- Before installing devices with strong electromagnetic interference, such as a transformer, install a shielding device for the equipment to prevent malfunction.
- Install the equipment onto an incombustible object such as a metal. Keep the equipment away from combustible objects. Failure to comply will result in a fire.

 CAUTION

- Cover the top of the equipment with a piece of cloth or paper during installation. This is to prevent unwanted objects such as metal chippings, oil, and water from falling into the equipment and causing faults. After installation, remove the cloth or paper on the top of the equipment to prevent over-temperature caused by poor ventilation due to blocked ventilation holes.
- Resonance may occur when the equipment operating at a constant speed executes variable speed operations. In this case, install the vibration-proof rubber under the motor frame or use the vibration suppression function to reduce resonance.

Wiring DANGER

- Equipment installation, wiring, maintenance, inspection, or parts replacement must be performed only by professionals.
- Before wiring, cut off power connections with all equipment. Residual voltage exists after power cut-off. Therefore, wait at least the time designated on the equipment warning label before further operations. Measure the DC voltage of the main circuit and make sure it is below the safe voltage, otherwise there will be the danger of electric shock.
- Do not perform wiring, remove the equipment cover, or touch the circuit board with power ON. Failure to comply will result in an electric shock.
- Check that the equipment is grounded properly. Failure to comply will result in an electric shock.

 WARNING

- Do not connect the input power supply to the output end of the equipment. Failure to comply will result in equipment damage or even a fire.
- When connecting a drive to the motor, check that the phase sequences of the drive and motor terminals are consistent to prevent reverse motor rotation.
- Cables used for wiring must meet cross sectional area and shielding requirements. The shield of the cable must be reliably grounded at one end.
- Fix the terminal screws with the tightening torque specified in the user guide. Improper tightening torque may overheat or damage the connecting part, resulting in a fire.
- After wiring is done, check that all cables are connected properly and no screws, washers or exposed cables are left inside the equipment. Failure to comply may result in an electric shock or equipment damage.

 CAUTION

- During wiring, follow the proper electrostatic discharge (ESD) procedure, and wear an antistatic wrist strap. Failure to comply will damage the equipment or the internal circuits of the equipment.
- Use shielded twisted pairs for the control circuit. Connect the shield to the grounding terminal of the equipment for grounding purpose. Failure to comply will result in equipment malfunction.

Power-on



DANGER

- Before power-on, check that the equipment is installed properly with reliable wiring and the motor can be restarted.
- Check that the power supply meets equipment requirements before power-on to prevent equipment damage or a fire.
- After power-on, do not open the cabinet door or protective cover of the equipment, touch any terminal, or disassemble any unit or component of the equipment. Failure to comply will result in an electric shock.



WARNING

- Perform a trial run after wiring and parameter setting to ensure the equipment operates safely. Failure to comply may result in personal injuries or equipment damage.
- Before power-on, make sure that the rated voltage of the equipment is consistent with that of the power supply. Failure to comply may result in a fire.
- Before power-on, check that no one is near the equipment, motor, or machine. Failure to comply may result in death or personal injuries.

Operation



DANGER

- The equipment must be operated only by professionals. Failure to comply will result in death or personal injuries.
- Do not touch any connecting terminals or disassemble any unit or component of the equipment during operation. Failure to comply will result in an electric shock.



WARNING





- Do not touch the equipment casing, fan, or resistor with bare hands to feel the temperature. Failure to comply may result in personal injuries.
- Prevent metal or other objects from falling into the equipment during operation. Failure to comply may result in a fire or equipment damage.

Maintenance



DANGER

- Equipment installation, wiring, maintenance, inspection, or parts replacement must be performed only by professionals.
- Do not maintain the equipment with power ON. Failure to comply will result in an electric shock.
- Before maintenance, cut off all the power supplies of the equipment and wait for at least the time designated on the equipment warning label.
- In case of a permanent magnet motor, do not touch the motor terminals immediately after power-off because the motor terminals will generate induced voltage during rotation even after the equipment power supply is off. Failure to comply will result in an electric shock.

 WARNING <ul style="list-style-type: none"> • Perform routine and periodic inspection and maintenance on the equipment according to maintenance requirements and keep a maintenance record.
Repair
 DANGER <ul style="list-style-type: none"> • Equipment installation, wiring, maintenance, inspection, or parts replacement must be performed only by professionals. • Do not repair the equipment with power ON. Failure to comply will result in an electric shock. • Before inspection and repair, cut off all the power supplies of the equipment and wait for at least the time designated on the equipment warning label.
 WARNING <ul style="list-style-type: none"> • Submit the repair request according to the warranty agreement. • When the fuse is blown or the circuit breaker or earth leakage current breaker (ELCB) trips, wait for at least the time designated on the equipment warning label before power-on or further operations. Failure to comply may result in death, personal injuries or equipment damage. • When the equipment is faulty or damaged, the troubleshooting and repair work must be performed by professionals that follow the repair instructions, with repair records kept properly. • Replace quick-wear parts of the equipment according to the replacement instructions. • Do not use damaged equipment. Failure to comply may result in death, personal injuries, or severe equipment damage. • After the equipment is replaced, check the wiring and set parameters again.
Disposal
 WARNING <ul style="list-style-type: none"> • Dispose of retired equipment in accordance with local regulations and standards. Failure to comply may result in property damage, personal injuries, or even death. • Recycle retired equipment by observing industry waste disposal standards to avoid environmental pollution.

Additional Precautions

Dynamic brake

- Dynamic braking can only be used for emergency stop in case of failure and sudden power failure. Do not trigger failure or power failure frequently.
- Ensure that the dynamic braking function has an operation interval of more than 5 minutes at high speed, otherwise the internal dynamic braking circuit may be damaged.

- Dynamic braking is common in rotating mechanical structures. For example, when a motor has stopped running, it keeps rotating due to the inertia of its load. In this case, this motor is in the regenerative state and short-circuit current passes through the dynamic brake. If this situation continues, the drive, and even the motor, may be burned.

Safety Label

For safe equipment operation and maintenance, comply with the safety labels on the equipment. Do not damage or remove the safety labels. See the following table for descriptions of the safety labels.

Safety Label	Description
 <p>危険 DANGER</p> <p>高压注意 Hazardous Voltage</p> <p>高温注意 High Temperature</p>	<ul style="list-style-type: none"> • Never fail to connect the protective earth (PE) terminal. Read through the guide and follow the safety instructions before use. • Never fail to connect Protective Earth (PE) terminal. Read the manual and follow the safety instructions before use. • Do not touch terminals within 15 minutes after disconnecting the power supply to prevent the risk of electric shock. • Do not touch terminals with 15 minutes after Disconnect the power. Risk of electrical shock. • Do not touch the heatsink with power ON to prevent the risk of burn. • Do not touch heatsink when power is ON. Risk of burn.

1 Precautions

- Observe the installation direction described in this guide. Failure to comply may result in equipment fault or damage.
- Do not install or operate damaged or defective equipment. Failure to comply will result in physical injury.
- Do not install the equipment in environments exposed to water splashes or corrosive gases. Failure to comply will result in equipment fault.
- Do not install the equipment near inflammable gases or combustible objects. Failure to comply will result in a fire or electric shock.
- Install the equipment inside a fire-proof cabinet that provides electrical protection. Failure to comply may result in a fire.
- Reserve specified clearance between the servo drive and its adjacent machines and the interior surface of the control cabinet. Failure to comply will result in a fire or equipment fault.
- Do not put heavy objects on the equipment. Failure to comply may result in physical injury or equipment damage.
- Do not impose large impact on the equipment. Failure to comply may result in equipment damage.
- Do not block the air inlet/outlet of the equipment or allow unwanted objects to fall into the equipment. Failure to comply may result in a fire or equipment fault.

2 Installation Flow Chart

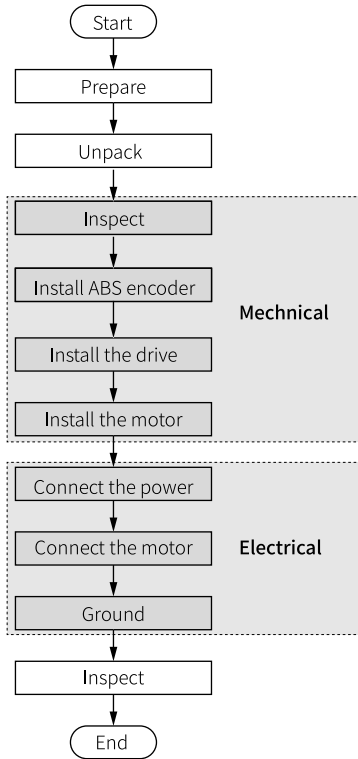

Figure 2-1 Installation Flow Chart

Note

The illustration presents the recommended installation procedure. You can adjust the procedure as appropriate.

3 Preparation

3.1 Installation Environment

Table 3-1 Environment requirement

Item	Requirement
Installation location	Indoors
Grid overvoltage	Overvoltage Class III (OVC III).
Altitude	<p>The maximum altitude is 2000 m.</p> <ul style="list-style-type: none"> • For altitudes not higher than 1000 m, derating is not required. • Derating is required for altitudes above 1000 m (derate 1% for every additional 100 m). • For altitudes above 2000 m, contact Inovance.
Temperature	<ul style="list-style-type: none"> • Mounting/Operating temperature: 0°C to +55°C For temperatures between 0°C to 45°C, derating is not required. For temperatures above 45°C, derate 2% for every additional 1°C. • Storage/Transportation temperature: -40°C to +70°C. • To improve the reliability of the machine, use the servo drive in environments without dramatic temperature change. • When installing the servo drive into an enclosed environment such as a control cabinet, use a cooling fan or air conditioner to keep the temperature of the inlet air below 45°C. Failure to comply will result in overheat or fire. • Install the servo drive on the surface of an incombustible object and leave sufficient surrounding space for heat dissipation. • Take measures to prevent the servo drive from being frozen.
Ambient humidity	Below 90% RH (no condensation)
Storage humidity	Below 90% RH (no condensation)
Vibration resistance	<p>Operation:</p> <ul style="list-style-type: none"> • 5 Hz–8.4 Hz: 3.5 mm displacement • 8.4 Hz–200 Hz: 1g <p>Product package:</p> <ul style="list-style-type: none"> • 5 Hz–100 Hz: 0.01g²/Hz • 200 Hz: 0.001g²/Hz • Grms = 1.14 g
Impact resistance	Below 19.6m/s ²

Item	Requirement
IP rating	IP20.
Environment	<p>Pollution Degree 2 and below</p> <p>Install the servo drive in a place that meets the following requirements:</p> <ul style="list-style-type: none"> • Free from direct sunlight, dust, corrosive gas, explosive and inflammable gas, oil mist, vapor, water drop, and salty element • Insusceptible to vibration (away from equipment that may generate strong vibration, such as a punch press) • Free from unwanted objects such as metal powder, oil, and water inside the servo drive • Free from radioactive substances, combustible materials, harmful gases and liquids, and salt corrosion • Away from combustible materials such as wood • Do not use the equipment in vacuum.

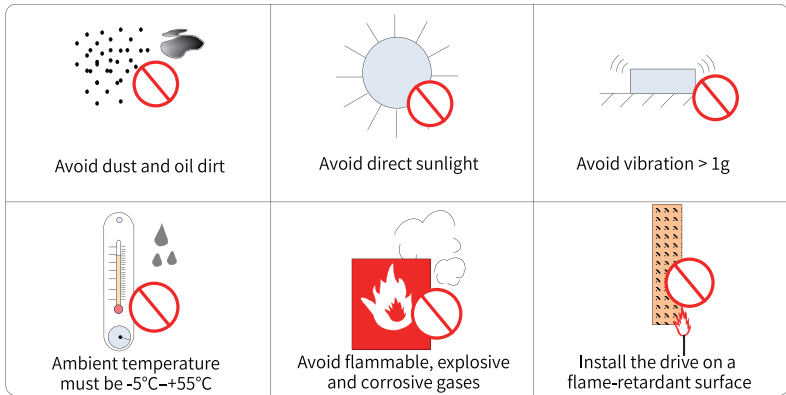

Figure 3-1 Environment requirements

3.2 Installation Clearance

Servo drives in different power ratings require different installation clearances. When installing multiple servo drives side by side, it is recommended to reserve a clearance of at least 10 mm (0.39 in.) between every two servo drives and a clearance of at least 80 mm (3.15 in.) above and below each servo drive for heat dissipation.

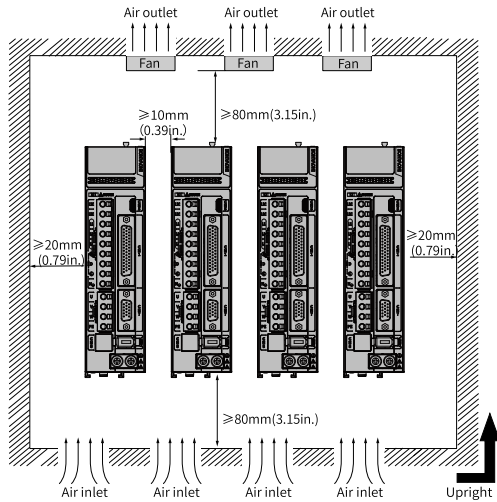

Figure 3-2 Clearance for side-by-side installation

Servo drives rated at 0.2 kW to 0.4 kW support compact installation, in which a clearance of at least 1 mm (0.04 in.) must be reserved between every two servo drives. When adopting compact installation, derate the load rate to 75%.

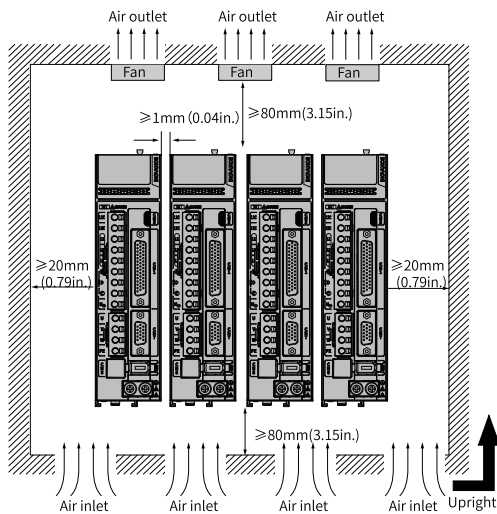

Figure 3-3 Clearance for compact installation

Servo drives rated at 0.75 kW to 7.5 kW support zero-clearance installation between every two servo drives, without the need for derating.

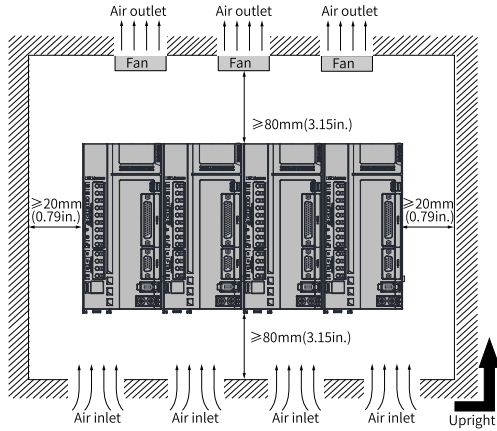

Figure 3-4 Zero-clearance installation

3.3 Installation Dimensions

Servo Drives in Size A (Rated Power: 0.2 kW to 0.4 kW): SV670PS1R6I, SV670PS2R8I

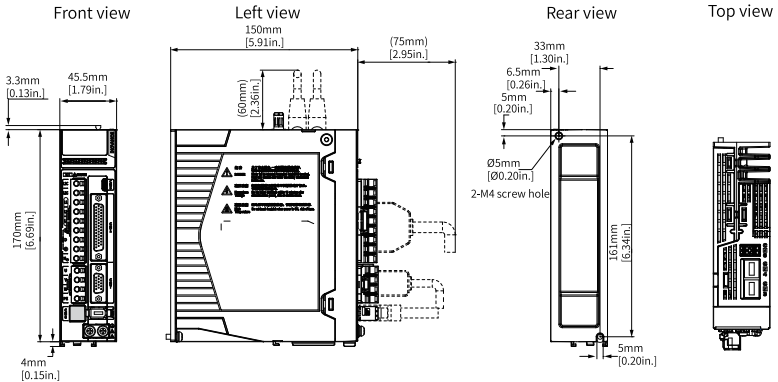

Figure 3-5 Dimension drawing of servo drives in size A

Fixing screws: 2-M4; recommended tightening torque: 1.2 N·m

Weight: 0.96 kg

Servo Drives in Size C (Rated Power: 0.75 kW to 1.5 kW): SV670PS5R5I, SV670PS7R6I, SV670PT3R5I, SV670PT5R4I

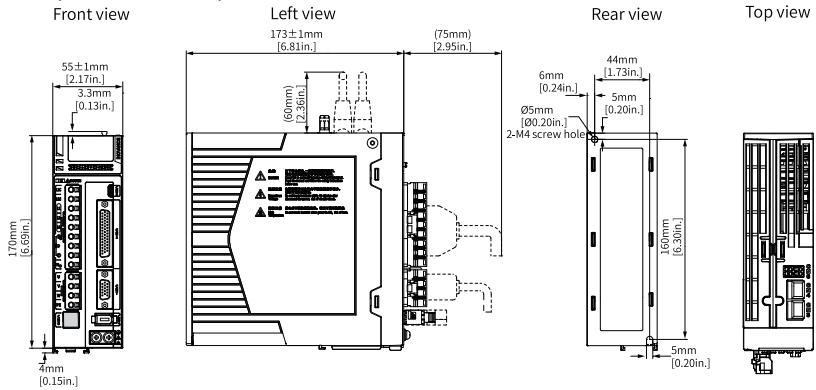

Figure 3-6 Dimension drawing of servo drives in size C

Fixing screws: 2-M4; recommended tightening torque: 1.2 N·m

Weight: 1.3 kg

Servo Drives in Size D (Rated Power: 1.5 kW to 3.0 kW): SV670PS012I, SV670PT8R4I, SV670PT012I

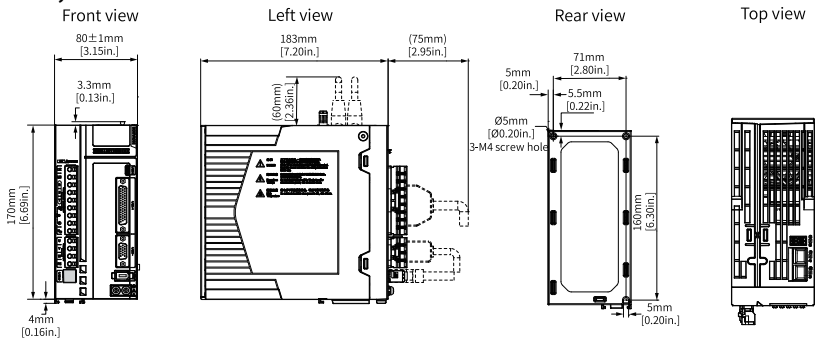

Figure 3-7 Dimension drawing of servo drives in size D

Fixing screws: 3-M4; recommended tightening torque: 1.2 N·m

Weight: 1.8 kg

Servo Drives in Size E (Rated Power: 2.0 kW to 7.5 kW): SV670PS018I, SV670PS022I, SV670PS027I, SV670PT017I, SV670PT021I, SV670PT026I

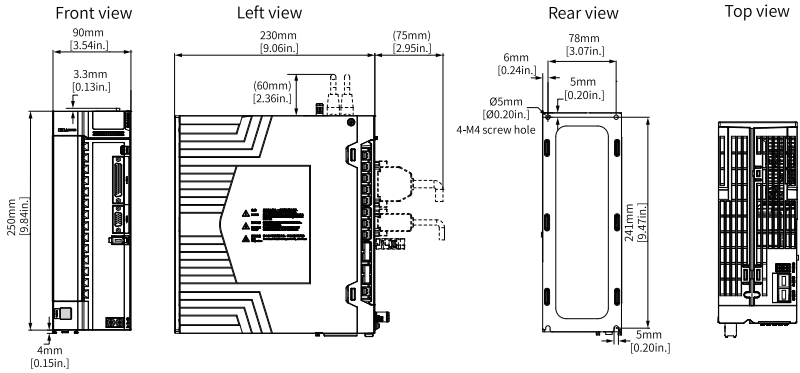

Figure 3-8 Dimension drawing of servo drives in size E

Fixing screws: 4–M4; recommended tightening torque: 1.2 N·m

Weight: 3.6 kg

3.4 Optional Parts

Fuse and circuit breaker



Caution

To prevent electric shock, when the fuse is blown or the circuit breaker trips, wait for at least the time designated on the warning label before powering on the drive or operating peripheral devices. Failure to comply can result in death, severe personal injury, or equipment damage.

To comply with CE/UL certification, install a fuse/circuit breaker on the input side of the drive to prevent accidents caused by short circuit in the internal circuit.

AC Input Reactor

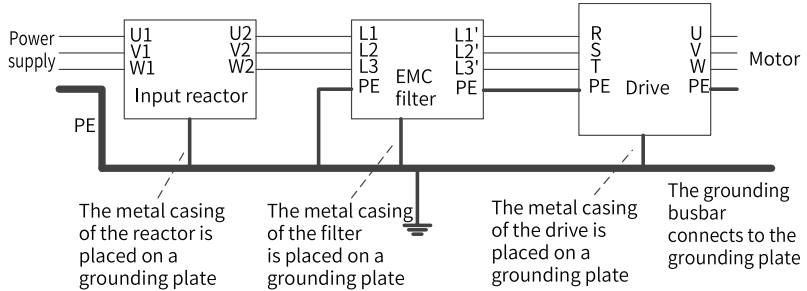

Figure 3-9 Installing the AC input reactor

EMC filter

Install the filter near the input terminals of the drive. The cable between the filter and the drive must be shorter than 30 cm. Connect the grounding terminal of the filter together with the grounding terminal of the drive. Ensure the filter and the drive are installed onto the same conductive mounting surface that is connected to the main grounding of the control cabinet.

3.5 Cable Preparation

There are many cables connecting to the drive, including the power supply cable, power cable, encoder cable, control cable and communication cable. For detailed cable specifications, see the hardware guide.

If you have special requirements on the cables, contact Inovance.

Crimping

The following figure illustrates how to crimp a cable. The crimping method may vary with different cable types.

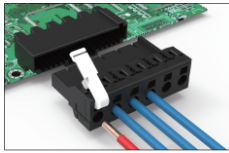

① Install the accessory

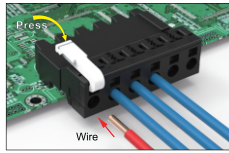

② Press the accessory

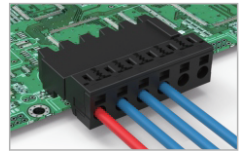

③ Insert the wire

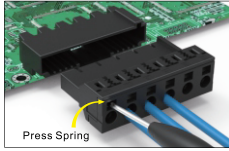

④ Press the contact with a screwdriver

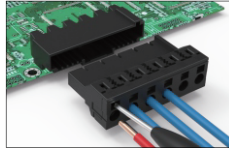

⑤ Insert the wire

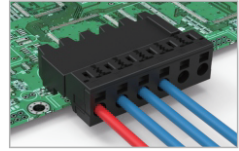

⑥ Pull out the screwdriver

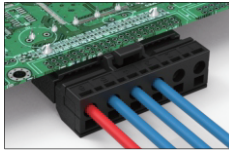

⑦ Disconnect the terminal

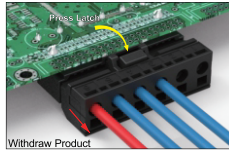

⑧ Press the lock

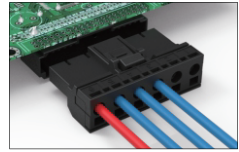

⑨ Pull out the terminal

Figure 3-10 Crimping a cable

4 Unpacking Inspection

Check the following items upon unpacking.

Items	Description
Check whether the delivered product is consistent with your order.	Check whether the servo drive model and specifications comply with your order. For the size of the packing box, see "Table 4-1 " on page 21. The deliverables include the product, cushion, carton box, and screw bag, as shown in "Figure 4-1 " on page 21 .
Check whether the product is intact.	Check whether the product delivered is in good condition. If there is any missing or damage, contact Inovance or your supplier immediately.

Table 4-1 Dimensions of the outer packing box

Size	Model SV670P****I	Outer Width (mm)	Outer Height (mm)	Outer Depth (mm)	Weight (kg)
Size A	S1R6, S2R8	250.0	110.0	200.0	1.13
Size C	S5R5, S7R6	235.0	125.0	215.0	1.5
Size D	S012, T8R4, T012	235.0	150.0	225.0	2.0
Size E	S018, S022, S027, T017, T021, T026	320.0	170.0	280.0	3.9

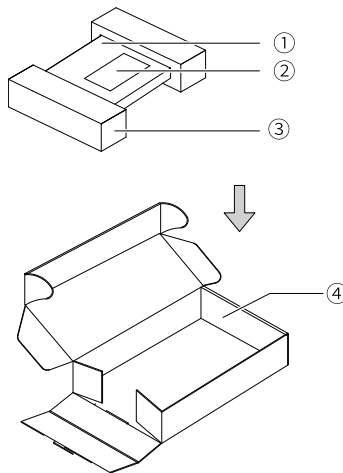

Figure 4-1 Contents inside the packing box

No.	Name
①	Product
②	Terminal accessory package

No.	Name
③	Cushion
④	Carton box

Table 4-2 Terminal accessory package list

Material Code	Name	Quantity
15210577	Plug-in terminal block-plug-spring clamp wiring-9P-black-with safety lock	1
15210695	Plug-in terminal block-plug-spring clamp wiring-4P-black	1
15220274	Jumper bar-16A-pluggable bridge	1
19020818	Label-CV100 blank QR code (RoHS)	1
19021377	Labels-labels for servo drive terminals	1
19033058	Bag-Ziplock bag for screws delivered with the 60 kW hybrid bus motor inverter	1
21020021	Plastic parts-plug wiring key-for use with servo drive power plug	1

If you need to purchase the terminal accessory package separately, please contact Inovance. For the material code of the accessory package for each model, refer to ["Table 4-3 " on page 22.](#)

Table 4-3 Material code of the accessory package for each model

Material Code	Name
98050613	Accessories (sale)-S6-C105-SV670P terminal accessory package
98050614	Accessories (sale)-S6-C104-SV670P size A terminal accessory package

5 机械安装

5.1 Safety Cautions

Table 5-1 Installation Precautions

Item	Description
Installation Method	<ul style="list-style-type: none"> ● Install the servo drive vertically and upward to facilitate heat dissipation. For installation of multiple servo drives inside the cabinet, install them side by side. For dual-row installation, install an air guide plate. ● Make sure the servo drive is installed vertically to the wall. Cool the servo drive down with natural convection or a cooling fan. Secure the servo drive to the mounting surface through two to four mounting holes (the number of mounting holes depends on the capacity of the servo drive). ● Install the servo drive vertically to the wall, with its front (actual mounting face) facing the operator. ● The mounting bracket (if needed) must be made of incombustible materials.
Cooling	As shown in "3.3 Installation Dimensions" on page 16 , reserve sufficient space around the servo drive to ensure a good heat dissipation through the cooling fan or natural convection. Take the heat dissipated by other devices inside the cabinet into consideration. Install a cooling fan to the upper part of the servo drive to avoid excessive temperature rise in a certain area, keeping an even temperature inside the control cabinet.
Grounding	Ground the grounding terminal properly. Failure to comply may result in electric shock or malfunction due to interference.

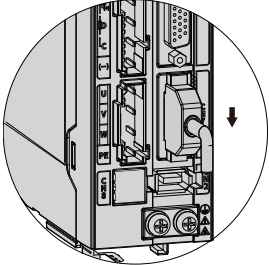
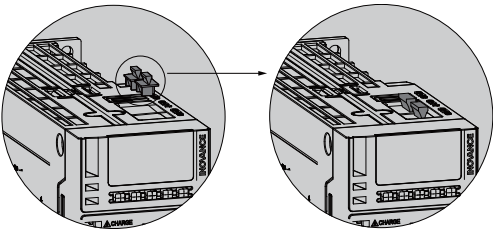
Item	Description
Wiring Requirements	<p>As shown in the figure below, route the servo drive cables downwards to prevent liquid from flowing into the servo drive along the cables.</p>  <p style="text-align: center;">Route the cable as indicated by the arrow</p>
Dust-proof cover (included in the standard configuration)	<p>Insert the dust-proof cover into the communication port (CN3/ CN4) not in use. This is to prevent unwanted objects, such as solids or liquids, from falling into the servo drive and resulting in faults.</p> <p>Each servo drive is delivered with two dust-proof covers inserted into the communication ports by default. You can place an order for more dust-proof covers as needed (model: NEX-02-N2B; manufacturer: PINGOOD).</p>  <p>Note:</p> <ul style="list-style-type: none"> • Dust-proof cover: Prevents unwanted objects, such as solids or liquids, from falling into the servo drive and resulting in faults. • Dust-proof covers are delivered along with the servo drive. Keep the dust-proof covers in a proper place.

5.2 Pre-Inspection

Table 5-2 Inspection Checklist

No.	Description	Yes
1	The delivered product is consistent with your order.	<input type="checkbox"/>
2	No deformation or cracks are present on the casing.	<input type="checkbox"/>

No.	Description	Yes
3	All screws are in position and tightened.	<input type="checkbox"/>
4	The signal terminal is free from fracture, foreign objects and bent pins.	<input type="checkbox"/>

5.3 Installing the Absolute Encoder Battery

The optional S6-C4A battery box contains the following items:

- One plastic case.
- One battery (3.6 V, 2,600 mAh).
- Terminal block and crimping terminal.

Installing the battery box

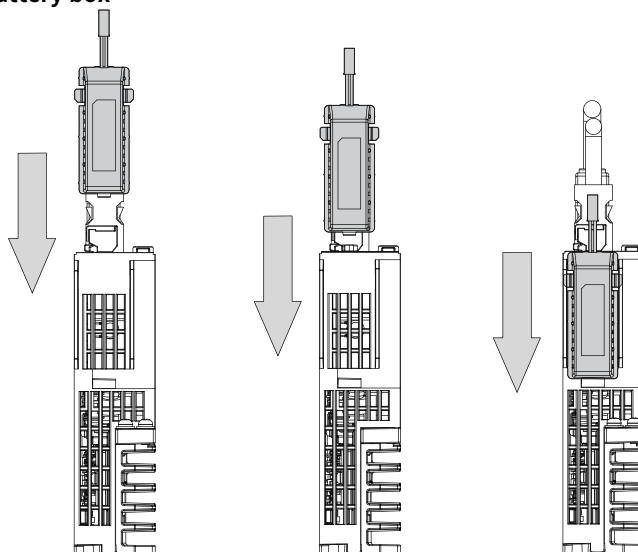
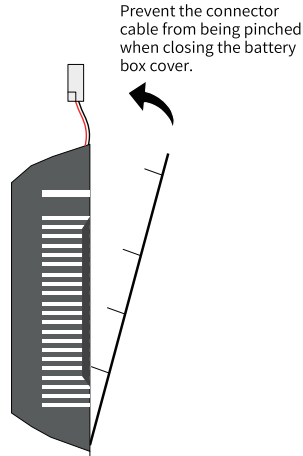

Figure 5-1 Installing the battery box (bottom view)

Removing the battery box

The battery may generate leakage liquid after long-term use. Replace it every two years. Remove the battery box in steps shown in the preceding figure, but in the reverse order.

When closing the battery box cover, prevent the connector cable from being pinched.



Improper use of the battery may result in liquid leakage which corrodes the components or leads to battery explosion. Observe the following precautions during use:

 **Caution**

- Insert the battery with polarity (+/-) placed correctly.
 - Leaving an idled or retired battery inside the device may lead to electrolyte leakage. The electrolyte inside the battery is highly corrosive, not only corroding surrounding components but also incurring the risk of short circuit. It is recommended to replace the battery every 2 years.
 - Do not disassemble the battery because the internal electrolyte may spread out and result in personal injury.
 - Do not throw a battery into the fire. Failure to comply may result in an explosion.
 - Do not short-circuit the battery or strip off the battery case. Prevent terminals (+) and (-) of the battery from coming into contact with the metal. Contact with the metal can result in a high current, not only weakening the battery power, but also incurring the risk of explosion due to severe heating.
 - This battery is not rechargeable.
 - Dispose of the retired battery according to local regulations.
-

5.4 Mounting the Drive

The servo drive supports backplate mounting only.

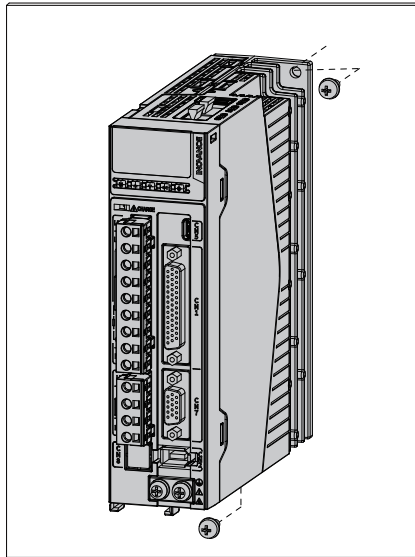

Figure 5-2 Backplate mounting

Note

- Servo drives in sizes A and C are secured by two screws, with one screw on the top and the other one at the bottom.
- Servo drives in size D are secured by three screws, with two screws on the top and another one at the bottom.
- Servo drives in size E are secured by four screws, with two screws on the top and the other two at the bottom.

5.5 Installing the Motor

Installation Direction

The MS1 series motor is flange-mounted. It can be mounted in three directions, as shown in the following figure.

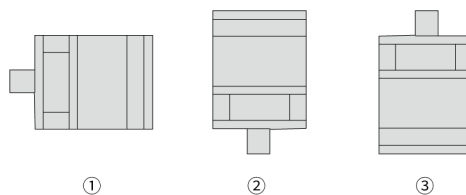

The motor can be horizontally or vertically mounted. When it is mounted in direction 3:

- Note the permissible axial force of the motor (gravity of the drive unit) and the IP rating requirement.
- If a oil seal is used, oil may enter the motor.
- Ensure that the direction is suitable for operation conditions.

Heat dissipation

The MS1 series motor is naturally cooled. The internal heat is consumed through heat conduction, heat radiation and natural convection. A heatsink is used for heat conduction. For details, see "[Installation cautions](#)" on page 28. To ensure adequate heat dissipation, at least 100 mm spacing between adjacent parts is recommended on three sides.

When the motor is used together with a reducer, the motor needs to be derated.

Installation cautions

The mechanical and electrical installation of the motor must be performed by trained professionals:

- Obey the data on the nameplate and the warning labels attached to the motor.
- Ensure that the environmental conditions of the installation site (such as temperature and installation height) meet the requirements. It is forbidden to use the motor in explosive environment.
- Thoroughly remove the preservative from the shaft extension with a commonly used solvent.
- To ensure heat dissipation, install a heat sink between the machine tool and the motor. The larger the heat sink, the better the heat dissipation. The recommended size and material of the heat sink are as follows:

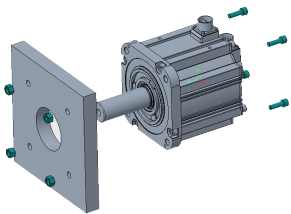

- MS1H1/MS1H4: 250 × 250 × 6 (mm) (aluminum)
- MS1H2-10C to 25C: 300 × 300 × 12 (mm) (steel)
- MS1H2-30C to 50C: 400 × 400 × 20 (mm) (steel)
- MS1H3-85B to 18C: 400 × 400 × 20 ((mm) (steel)
- MS1H3-29C to 75C: 360 × 360 × 25 ((mm) (aluminum)

Do not put an insulator, such as a pad, between the servo motor and heat sink, otherwise motor temperature will rise and the motor may fail.

- For vertical mounting with the shaft extension upwards, ensure that no liquid enters the upper bearing.
- When using a motor with an oil seal, you must lower the oil level to the lip of the oil seal.

- To prevent excessive wear of the oil seal, leave a small amount of oil on the lip for lubrication.
- The motor can only be installed on a flat, vibration-free and distortion-resistant support flange surface according to the specified structure.
- Use hexagon socket screws with strength grade of at least 8.8.
- When tightening the fixing screws, prevent the screws from deforming.
- Obey the recommended tightening torque values of motor flange fixing screws. See the following table "[Table 5-3 Recommended tightening torques for fixing screws](#)" on page 29.
- For motors with a flange of 180 mm or above, remove or tighten the lifting lugs after the motor is mounted.

Table 5-3 Recommended tightening torques for fixing screws

Flange Size	Screw Qty. and Size	Tightening Torque (in N·m)
40	2×M4	2.4
60	4×M5	4.7
80	4×M6	8
100	4×M6	8
130	4×M8	20
180	4×M12	65

Note

- To avoid damage to the motor, do not hit or squeeze the shaft extension.
- To avoid corrosion,
 - When cleaning rust and stains at the end of motor shaft, use ordinary detergent.
 - Keep detergent away from the bearings and seals.
- Do not soak the oil seal in the oil. Oil inside the servo motor may cause malfunction.

Installation of the brake motor

After the brake is energized, the electric excitation coil closes and the armature is released. After the power is cut off, the brake holds the motor shaft through a mechanical elastic device. The brake is only used for stopping the motor. Frequent use will shorten its service life. If it is not absolutely necessary, do not use it for emergency stop or deceleration.

The rated voltage of the brake is 24V DC \pm 10%. The minimum voltage that supplied on the connector at the motor side must be 24 V DC (-10%) to ensure the normal opening of the brake. When the maximum voltage of 24V DC (+10%) is exceeded, the

brake may be closed again. The voltage drop on the cable should be considered for long-distance brake cables. The approximate calculation of voltage drop ΔU of a copper cable is as follows:

$$\Delta U [V] = 0.042 \Omega \cdot \text{mm}^2/\text{m} (L/q) \cdot I_{\text{brake}}$$

Where: L = cable length (m), q = cross-sectional area of brake cable conductor (mm^2), I_{brake} = Brake DC current (A)

The close time and open time of the brake vary with the discharge circuit. Ensure that the operation delay time is obtained from the actual device.

Avoid starting the motor repeatedly for a short time when the brake is still connected. Therefore, the switching time of the brake and the switching time of the relay should be considered in the drive control circuit or the enabling circuit.

For applications where the gravity shaft or mechanical parts may drop, you must take protection measures, for example, using an anti-drop mechanism with dual safety structure.

Note

- When the motor with a brake is accelerating, stopping or running at low speed, the rotating disc of the brake will produce a slight friction sound, which is not a fault or abnormality.
 - Because the brake backlash will occur when the brake is not electrified, there will be a tiny return clearance in the rotating direction of the motor shaft, which is normal.
-

Mechanical connection

Install and remove transmission units, such as couplings, gears and pulleys, only using appropriate tools.

- Use the threaded hole on the shaft extension;
- Heat the transmission unit when necessary;
- Use a washer to protect the shaft extension center during disassembly;
- The motor with a keyway has been tested for half-key balance before delivery. If necessary, you can perform full balancing for the motor with transmission units.

Coupling

- Use a dedicated flexible coupling. It is recommended to use a double leaf spring coupling that allow a certain eccentric angle.
- To prevent malfunction, use a coupling with a proper size.
- Although the centering of the coupling varies with the rotating speed and the type of the coupling, ensure that the coaxiality of the load at both ends of the coupling is $< 0.03 \text{ mm}$.

Belt connection

- Select the appropriate belt according to the allowable radial load of the servo motor and the output power of the motor.
- When installing the belt, ensure that its tension is lower than the specified allowable radial load.
- See the instructions of the belt manufacturer for detailed installation precautions.

5.6 Post-Inspection

Table 5-4 Inspection Checklist

No.	Description	Yes
1	Terminal screws are tightened to the specified torque and marked.	<input type="checkbox"/>
2	The servo drive and the external regenerative resistor are placed on incombustible objects.	<input type="checkbox"/>
3	No unwanted objects (such as cable terminals and metal chippings) that may cause short circuit are present inside or outside the servo drive.	<input type="checkbox"/>
4	The servo motor is installed properly. The motor shaft is connected to the machine securely.	<input type="checkbox"/>
5	The servo motor and the machine it is connected to are in good condition and ready to run.	<input type="checkbox"/>
6	The connector of the main circuit cable is crimped and installed firmly.	<input type="checkbox"/>

6 电气安装

6.1 Safety Cautions

- Observe the following requirements during wiring of the power supply and main circuit:
 - When the main circuit terminal is a connector, remove the connector from the servo drive before wiring.
 - Insert one cable into one cable terminal of the connector. Do not insert multiple cables into one cable terminal.
 - When inserting cables, take enough care to prevent the cable conductor burrs from being short circuited to the neighboring cable.
 - Insulate the connecting part of the power supply terminals to prevent electric shock.
 - Do not connect a 220 V servo drive to a 380 V power supply directly.
 - Install safety devices such as a circuit breaker to prevent short circuit in external circuits. Failure to comply may result in a fire.
 - Cut off the main circuit power supply and switch off the S-ON signal after an alarm signal is detected.
- Do not put heavy objects onto cables or pull cables with excessive force. Failure to comply may result in cable damage, leading to an electric shock.
- Use a power supply filter to reduce the electromagnetic interference on electronic devices surrounding the servo drive.

6.2 Wiring of the Power Supply

- Single-phase 220 V models: SV670PS1R6I, SV670PS2R8I, SV670PS5R5I, SV670PS7R6I and SV670PS012I

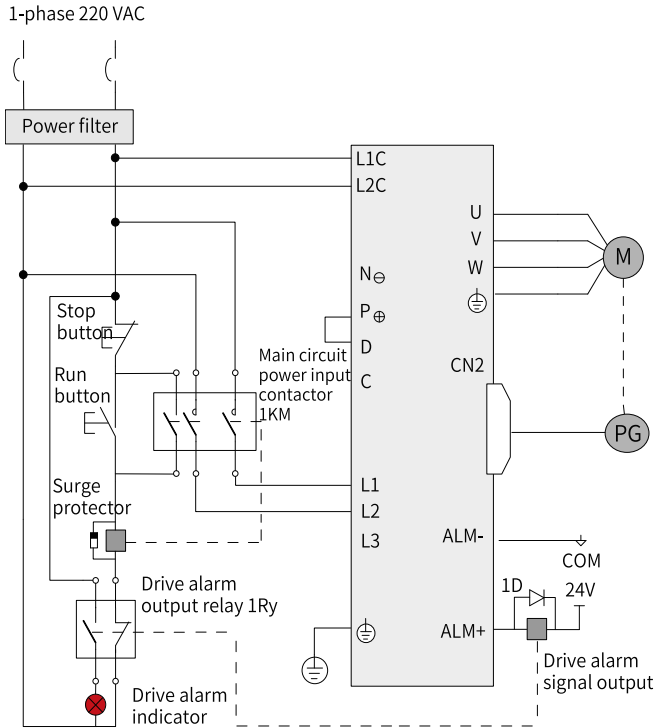

Figure 6-1 Main circuit wiring

Note

- 1KM: Electromagnetic contactor; 1Ry: Relay; 1D: Flywheel diode
- DO is set as alarm output (ALM+/-). When the servo drive alarms, the power supply will be cut off automatically. S1R6 and S2R8 are not configured with built-in regenerative resistors, if the regenerative resistor is needed, connect an external regenerative resistor between P⊕ and C.
- Three-phase 220 V models: SV670PS1R6I, SV670PS2R8I, SV670PS5R5I, SV670PS7R6I, SV670PS012I, SV670PS018I, SV670PS022I and SV670PS027I

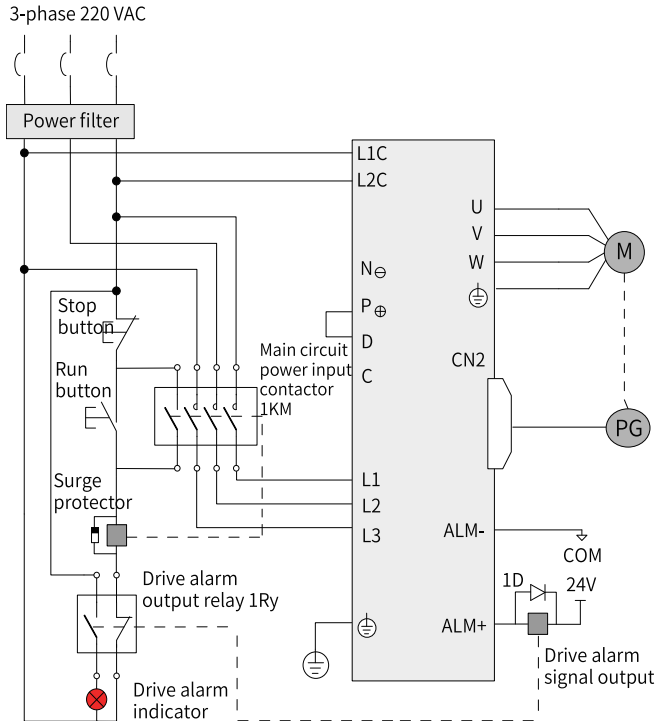

Figure 6-2 Main circuit wiring

Note

- 1KM: Electromagnetic contactor; 1Ry: Relay; 1D: Flywheel diode
- The DO is set as alarm output (ALM+/-). When the servo drive alarms, the power supply is cut off automatically and the alarm indicator lights up.
- Three-phase 380 V models: SV670PT3R5I, SV670PT5R4I, SV670PT8R4I, SV670PT012I, SV670PT017I, SV670PT021I, SV670PT026I

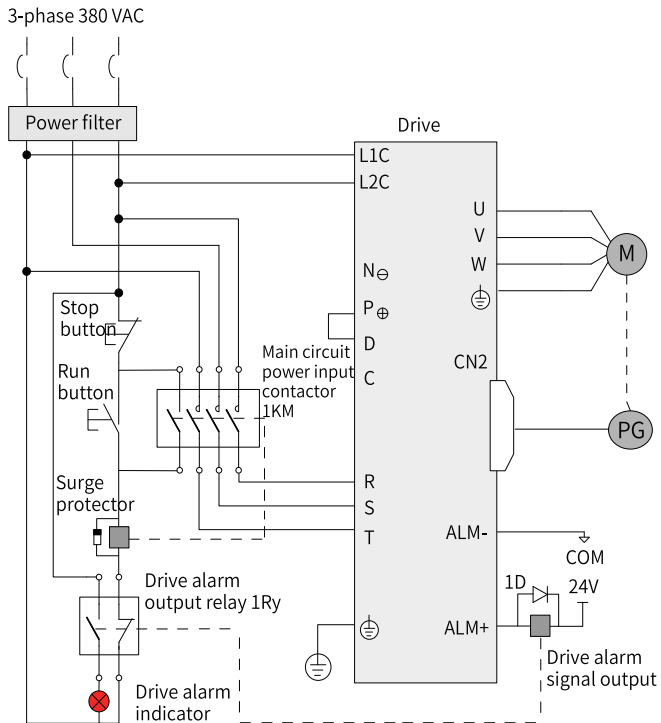

Figure 6-3 Main circuit wiring

Note

- 1KM: Electromagnetic contactor; 1Ry: Relay; 1D: Flywheel diode
- The DO is set as alarm output (ALM+/-). When the servo drive alarms, the power supply is cut off automatically and the alarm indicator lights up.

6.3 Wiring with the Motor

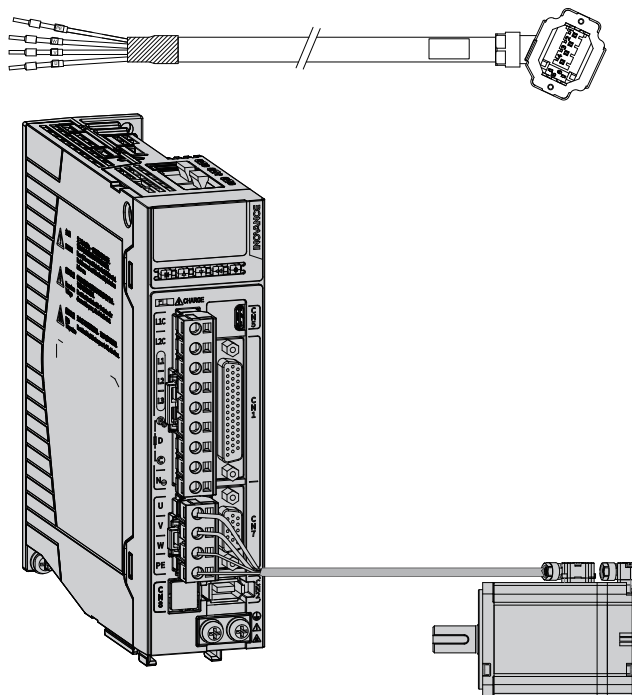

Figure 6-4 Wiring between the servo drive and terminal-type motor



Caution

To avoid flying start, ensure that the phase sequence is correct.

Table 6-1 Description of the power cable connector (motor side) for terminal-type motors

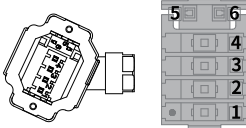
Flange Size ^[1]	Outline Drawing of the Connector	Terminal Pin Layout		
		Pin No.	Signal Name	Color
Terminal-type: 40 60 80	 <p>Black 6-pin connector</p>	1	PE	Yellow/ Green
		2	W	Red
		3	V	Black
		4	U	White
		5	Brake (polarity insensitive)	Brown
		6		Blue

Note

- [1] The flange size refers to the width of the mounting flange.
- Power cable colors are subject to the actual product. All cable colors mentioned in this guide refer to Inovance cable colors.

Table 6-2 Description of the pass-through power cable connector (motor side)

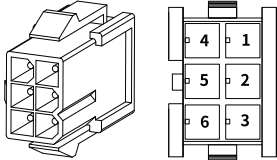
Flange Size ^[1]	Outline Drawing of the Connector	Terminal Pin Layout		
		Pin No.	Signal Name	Color
Pass-through type: 40 60 80	 <p>Black 6-pin connector Recommendation: Plastic housing: MOLEX-50361736 Terminal: MOLEX-39000061</p>	1	U	White
		2	V	Black
		4	W	Red
		5	PE	Yellow/ Green
		3	Brake (polarity insensitive)	Brown
		6		Blue

Note

- [1] The flange size refers to the width of the mounting flange.
- Power cable colors are subject to the actual product. All cable colors mentioned in this guide refer to Inovance cable colors.

Table 6-3 Description of the power cable connector (motor side)

Flange Size ^[1]	Outline Drawing of the Connector	Terminal Pin Layout		
		Pin No.	Signal Name	Color
100 130	 <p>20-18 connector MIL-DTL-5015 series 3108E20-18S military-spec connector</p>	B	U	Blue
		I	V	Black
		F	W	Red
		G	PE	Yellow/ Green
		C	Brake (polarity insensitive)	Red
		E		Black

Table 6-4 Description of the power cable connector (motor side)

Flange Size [1]	Outline Drawing of the Connector	Terminal Pin Layout		
		Pin No.	Signal Name	Color
180	 <p>20-22 connector</p> <p>MIL-DTL-5015 series 3108E20-22S military-spec connector</p>	A	U	Blue
		C	V	Black
		E	W	Red
		F	PE	Yellow/ Green
		B	Brake (polarity insensitive)	Red
		D		Black

Note

- [1] The flange size refers to the width of the mounting flange.
- Power cable colors are subject to the actual product. All cable colors mentioned in this guide refer to Inovance cable colors.

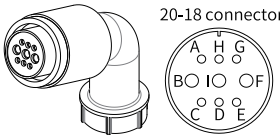
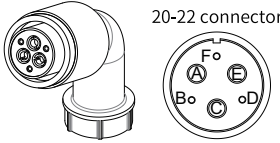
6.4 Post-Inspection

Table 6-5 Inspection Checklist

No.	Description	Yes
1	The power input terminals (L1C, L2C, L1, L2, L3, R, S, T) of the servo drive are connected properly.	<input type="checkbox"/>
2	P⊕, D, C and N⊖ are connected correctly.	<input type="checkbox"/>
3	The main circuit cables (U, V, W) of the motor are connected to the U/V/W terminals of the drive correctly.	<input type="checkbox"/>
4	No short circuit exists in the power input terminals (L1, L2, L3, R, S, T) or main circuit output terminals (U, V, W) of the servo drive.	<input type="checkbox"/>
5	The stress suffered by the cable is within the specified range.	<input type="checkbox"/>
6	The servo drive and servo motor are grounded properly.	<input type="checkbox"/>
7	All the wiring terminals are insulated properly.	<input type="checkbox"/>



19011868A01

Copyright © Shenzhen Inovance Technology Co., Ltd.

Shenzhen Inovance Technology Co., Ltd.

www.inovance.com

Add.: Inovance Headquarters Tower, High-tech Industrial Park,
Guanlan Street, Longhua New District, Shenzhen

Tel: (0755) 2979 9595

Fax: (0755) 2961 9897

Suzhou Inovance Technology Co., Ltd.

www.inovance.com

Add.: No. 16 Youxiang Road, Yuexi Town,
Wuzhong District, Suzhou 215104, P.R. China

Tel: (0512) 6637 6666

Fax: (0512) 6285 6720